

# Glycol Feed Systems



Where Innovation Flows

**Neptune™**



Neptune™ Glycol Feeders are designed for the addition of glycol solution to closed-loop chilled or hot water systems to maintain pressure in the loop by making up for losses that occur due to leakage.

Glycol addition is controlled by a pressure switch with adjustable low and high set points\*. When the pressure in the loop reaches the low set point, the pump begins to feed glycol into the system until the high-pressure set point is achieved and the switch stops the pump.

\*The standard pressure switch features the following ranges:  
Cut-in (low) range: 10-45 psi (0.7-3.1 bar); Cut-out (high) range: 20-60 psi (1.4-4.1 bar);  
Adjustable differential: 10-30 psi (0.7-2.1 bar). Other pressure switches are available.

## FEATURES AND BENEFITS

- 50 gallon (189 liters) polyethylene tank mounted in a steel frame
- Bronze rotary gear pump
- Float switch for low level pump shutoff and alarm
- NEMA 4X control panel includes:
  - Hand off auto selector switch for pump motor
  - Pump (on) indicator light
  - (Low) tank level indicator light
  - Dry contact for remote low-level indication
  - Power cord with plug, 115V AC (60Hz) or 230V AC (50Hz)
- Max pressure up to 100 psi (6.9 bar)
- Max capacity up to 1.5 gpm (5.7 L/h)

## OPTIONS

- Optional audible alarm (not watertight) and push-button silence available

# Glycol Feed Systems

## SELECTION CHART

MODEL	DESCRIPTION
G-50-1	Complete system including 1.5 gpm at 100 psi (5.7 L/min at 6.9 bar) pump and low-level light.
G-50-1A	Complete system including 1.5 gpm at 100 psi (5.7 L/min at 6.9 bar) pump, low level light and audible alarm.
G-50-2A	Complete system including two 1.5 gpm at 100 psi (5.7 L/min at 6.9 bar) pumps, low level light and audible alarm. Separate discharge and pressure switches allow feeding two separate closed-loop systems independently from a single tank.
LP	Option to furnish larger pump rated 3.75 gpm at 100 psi (14.2 L/min at 6.9 bar). Add "LP" to Model Number to specify larger pump; Example G-50-1-LP.

## MATERIALS OF CONSTRUCTION

### EACH DISCHARGE ASSEMBLY CONTAINS:

- 1/2" S40/ Brass/ Pipe w/ NPT Fittings
- 1/2" Ball Valve/ PVC
- 1/2" Check Valve/ Brass
- 1/2" Relief Valve/ Brass set at 100 psi (6.9 bar) w/PVC Return Line
- Pressure Gauge 0-100 psi (0-6.9 bar)
- Pressure Switch

### EACH SUCTION ASSEMBLY CONTAINS:

- 1/2" S80/ PVC Pipe w/ NPT Fittings & PVC Tubing
- 1/2" PVC Ball Valve
- 1/2" Cast Iron Y-Strainer

MODEL G-50-2A

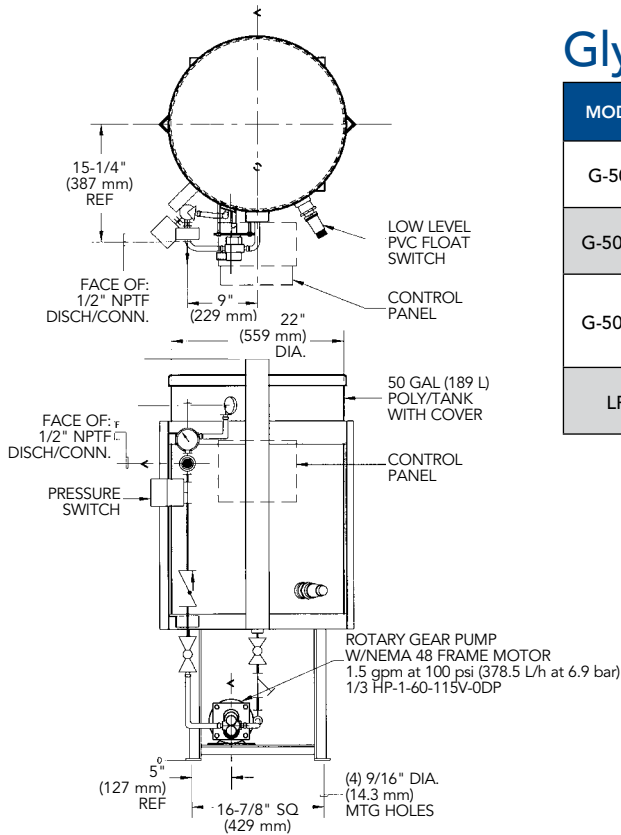

MODEL G-50-1 & G-50-1A

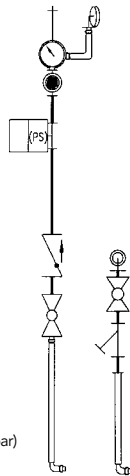
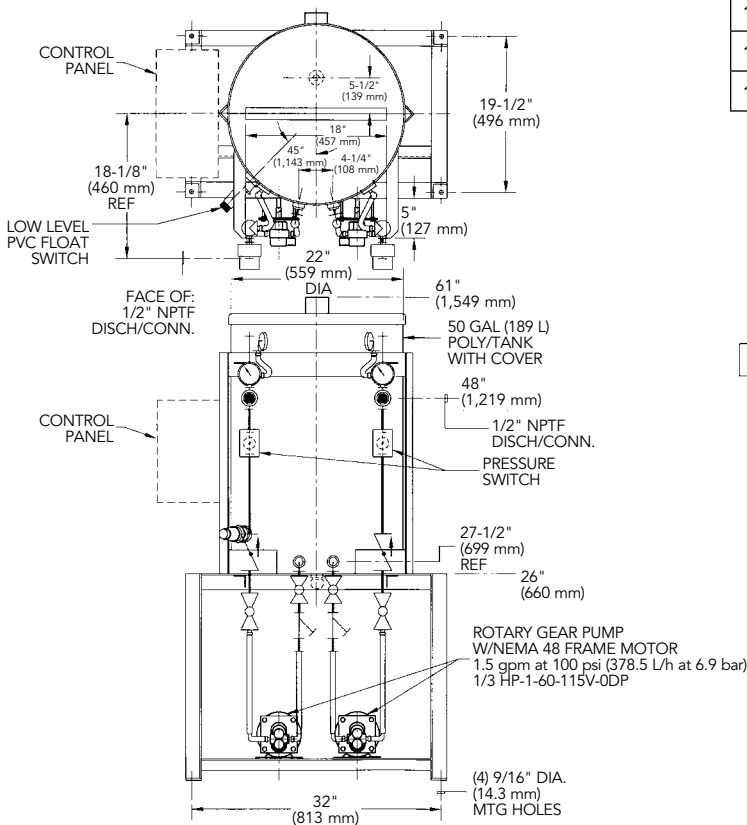

Model G-50-1

Where Innovation Flows



Distributed By:

PSG  
 22069 Van Buren Street  
 Grand Terrace, CA 92313-5651 USA  
 P: +1 (909) 422-1700 • F: +1 (909) 783-3440  
[psgdover.com/neptune](http://psgdover.com/neptune)