



INSTRUCTIONS 1001-H00 e

Section	1001
Effective	March 2016
Replaces	November 2013

Translation of the original instructions

C Series

Bellow monitoring system kit with capacitive detector assembly

INSTALLATION

OPERATION



This MOUVEX Instructions provides assistance for installation but it is not, in any circumstances, intended to replace the specific Instructions of the relevant equipment suppliers. Those Instructions must be read before fitting the equipment.



Z.I. La Plaine des Isles - F 89000 AUXERRE - FRANCE
Tel. : +33 (0)3.86.49.86.30 - Fax : +33 (0)3.86.49.87.17
contact@mouvex.com - www.mouvex.com

Your distributor :

1. OVERALL DIMENSIONS

1.1 Standard version

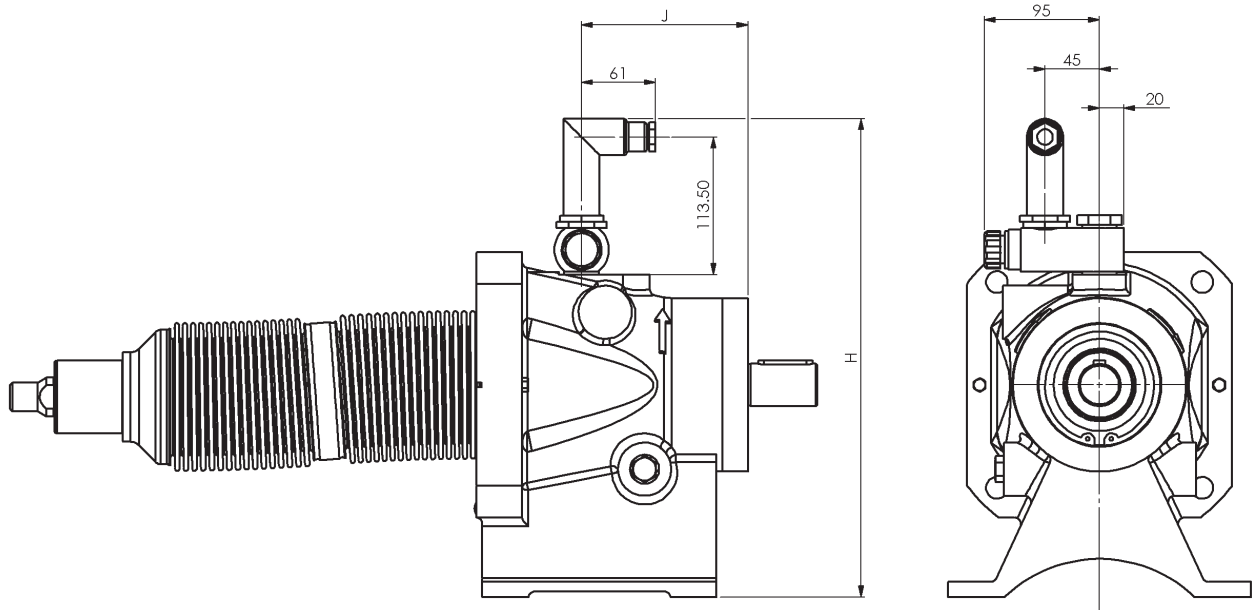

	C4-C8	C12-C18
H	310	400
J	60	140

1.2 HT version

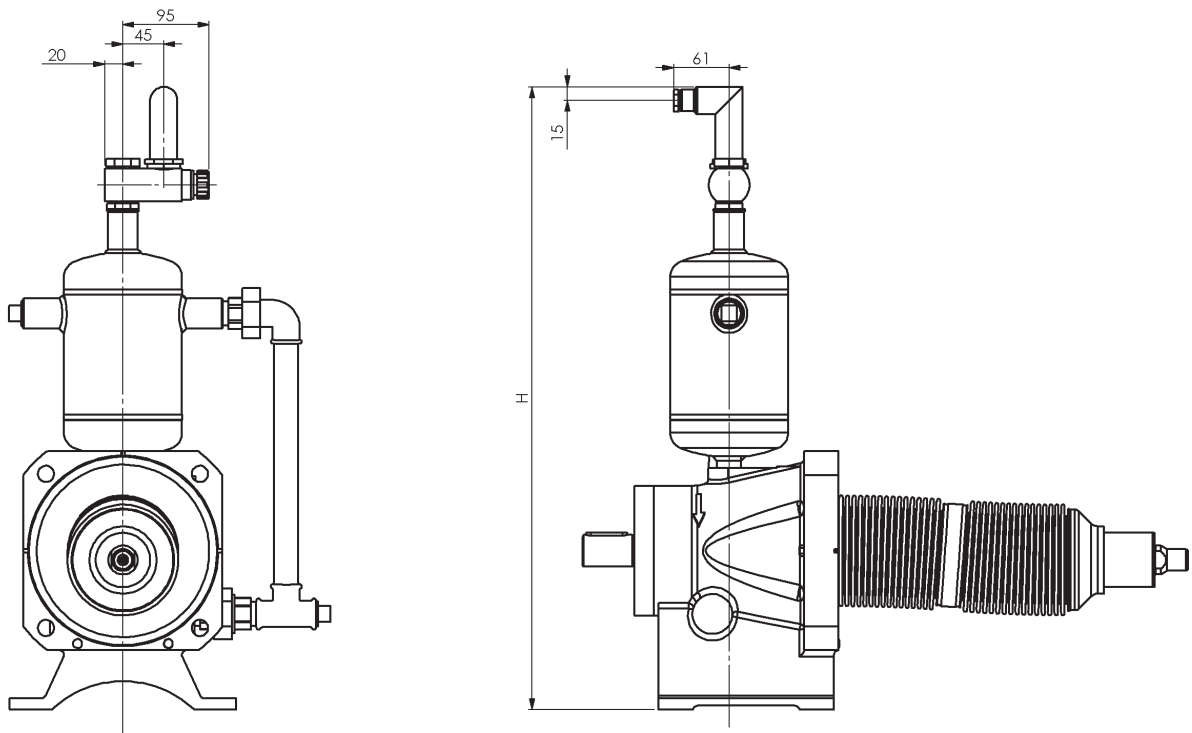

	C4 HT	C8 HT
H	550	550

2. EQUIPMENT SUPPLIED

Connection kit, composed of :

- 1 hollow screw,
- 1 coupling,
- 2 BS rings (1/2" gas),
- 1 male-female reducing nipple (3/4" x 1/4") (for HT pumps only).

Capacitive detectors :

- Non ATEX.....Ref. KI0024
- ATEXRef. KI5030 with barrier Ref. N0031A

3. INSTALLATION

3.1 Conditions for Installation of Pump

In order to ensure optimal detection and non-pollution of the product when the bellows are torn, the pump should be under pressure on suction side.

3.2 Installation of capacitive sensor

3.2.1 Remove the breather **715** from the bearing.

3.2.2 Screw the capacitive sensor **730**, with its plastic nuts, into the metal coupling **727**, sealing with PTFE compound (Loctite® 572* type).

NOTE: The sensor is to be oriented in accordance with the type of pump on which it is mounted, the latter being given for guidance purposes only.

3.2.3 Connect the sensor to the pump by means of the hollow screw **728** secured with BS rings **729**. If the sensor has a 3/4" thread, first fit the male-female reducing nipple **731** to the bearing surface applying PTFE compound (Loctite® 572* type). Use PTFE compound to lock all other threads.

3.2.4 Screw in the breather tube **715**.

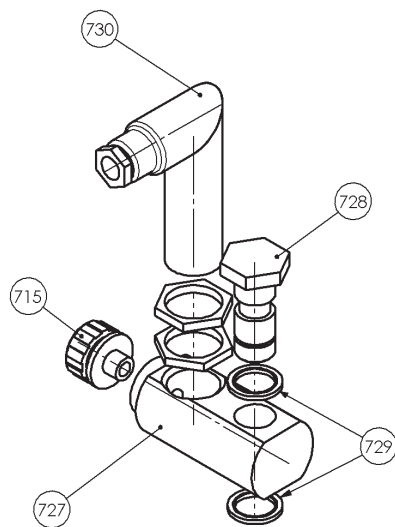

1/2" cyl. gas fitting
(C4_HT, C8_HT)

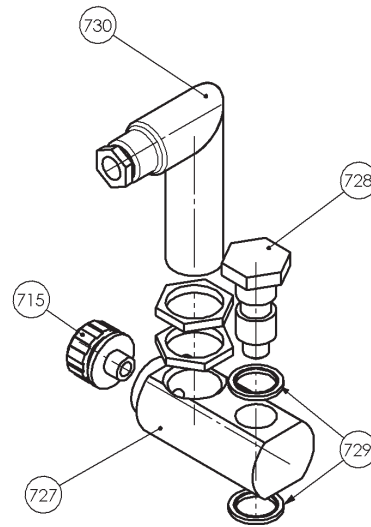

1/4" cyl. gas fitting
(C4_, C8_, C12_ & C18_)

NOTA :

- Capacitive sensor threads (and threads of reducing nipple for HT versions) sealed with PTFE compound (Loctite® 572* type)
- All other threads locked with PTFE compound (Loctite® 572* type).

* Loctite® is a registered trademark.

4. CONNECTION OF ELECTRICAL EQUIPMENT

Make the electrical connections in accordance with the Instructions manual supplied with the capacitive sensor.

Set the sensitivity of the sensor **730** to maximum, then reduce it gradually until the coupling **727** is no longer detected. Check the sensitivity by passing the screwdriver (used for making the setting) through the 1/4" gas port provided for the breather tube (leave the screwdriver in contact with the bottom so as to simulate a small flow of liquid). Transition from the open state to the closed state (and inversely) should be immediate when the screwdriver is inserted.

ATEX version :

Connect the detector to the intrinsic safety barrier.

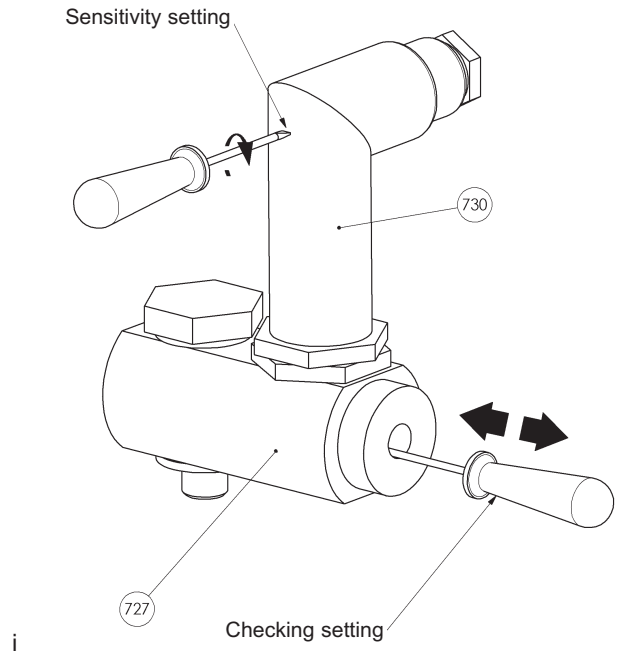

5. USE

As soon as oil is detected by the detector, stop the pump immediately, then check by visual inspection that oil is effectively present in the metal coupling (remove the breather tube if necessary).

If this is not the case, check the sensitivity setting.

In the case where a leak is effectively detected, disassemble the pump in accordance with the instructions in the Instructions manual and replace the bellows. Also check the state of the capacitive detector and, more particularly, that of the sensor and the seals which might have been damaged by contact with the product.