

| REV. | DESCRIPTION | BY | CHK. | APP. | DATE |
|------|---|----|------|------|------|
| A | RELEASED INTO PRODUCTION SEE ECN #G01031 | - | - | - | - |

NOTES: UNLESS OTHERWISE SPECIFIED

- DIMENSIONS AND TOLERANCES PER ASME Y14.5M-1994.
- * INDICATES DIMENSIONS AND/OR FEATURES MODIFIED ON CURRENT REVISION LEVEL.
- DIMENSIONS REFLECT STANDARD MFG TOLERANCES.
-  WEIGHTS ARE APPROXIMATE AND MAY VARY BASED ON MANUFACTURER'S MATERIALS AND PUMP CONFIGURATION.

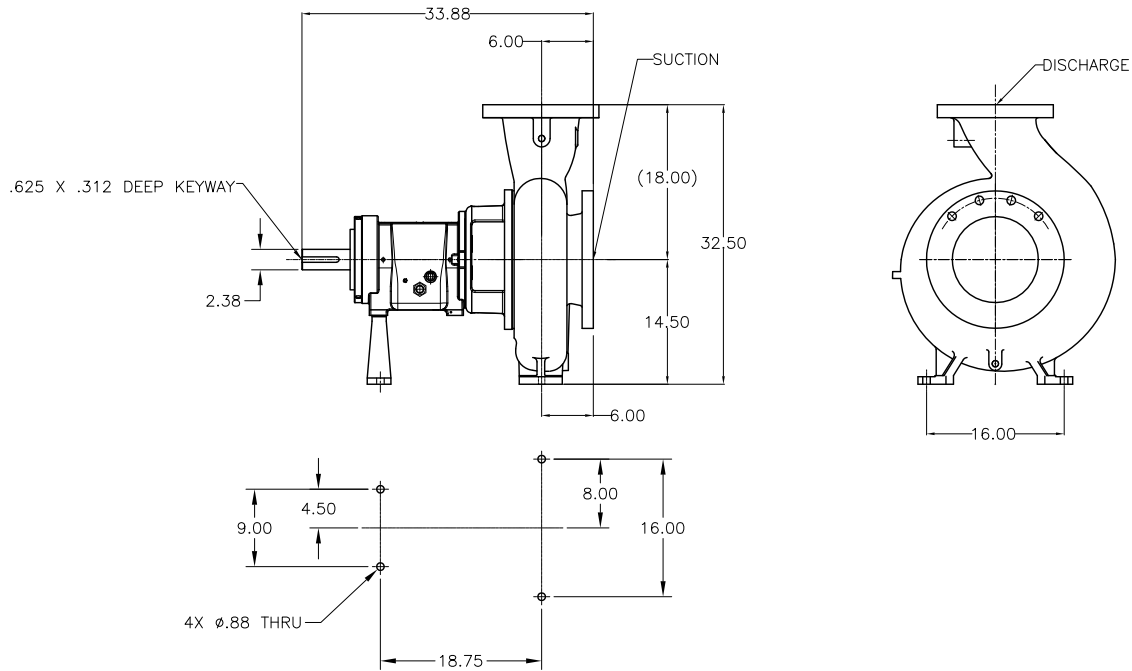

| OPTION | AVAILABLE OPTIONS |
|-------------------------------------|---------------------------------------|
| <input checked="" type="checkbox"/> | PUMP MATERIAL |
| | N6 DUCTILE IRON |
| | N6 DUCTILE IRON CASE / 91 SS IMPELLER |
| | 91 STAINLESS STEEL |
| | 20 HASTELLOY |
| | X4 CD4MCU SS |
| | OTHER: |
| | FLANGE FACE |
| | RAISED FACE |

| FLANGE OPTION DIMENSIONS | | | | | | | |
|-------------------------------------|-----------------------|-----------------|----------------------|--------------|-------------------|-----------|-----------|
| OPTION | NOMINAL PIPE SIZE | FLANGE DIAMETER | BOLT CIRCLE DIAMETER | NO. OF BOLTS | DIAMETER OF BOLTS | BOLT HOLE | FLANGE |
| <input checked="" type="checkbox"/> | 8" ASME 150# (SHOWN) | | | | | | DISCHARGE |
| | 8.00 | 13.50 | 11.75 | 8 | 0.75 | 0.88 | |
| <input checked="" type="checkbox"/> | 10" ASME 150# (SHOWN) | | | | | | SUCTION |
| | 10.00 | 16.00 | 14.25 | 12 | 0.88 | 1.00 | |
| <input checked="" type="checkbox"/> | 8" ASME 300# | | | | | | DISCHARGE |
| | 8.00 | 15.00 | 13.00 | 12 | 0.88 | 1.00 | |
| <input checked="" type="checkbox"/> | 10" ASME 300# | | | | | | SUCTION |
| | 10.00 | 17.50 | 15.25 | 16 | 1.00 | 1.13 | |
| <input checked="" type="checkbox"/> | 200 mm DIN PN16 | | | | | | DISCHARGE |
| | 200 mm | 340 mm | 295 mm | 12 | 20 mm | 23 mm | |
| <input checked="" type="checkbox"/> | 250 mm DIN PN16 | | | | | | SUCTION |
| | 250 mm | 405 mm | 355 mm | 12 | 24 mm | 28 mm | |

CERTIFIED FOR CONSTRUCTION

ONLY WHEN SIGNED

Signature _____

Date _____

Customer _____

Customer P.O. # _____

 PUMP WT. - 589 LBS

| | | | | | |
|---|--------------|---|--|---|--|
| DO NOT SCALE DRAWING UNLESS OTHERWISE SPECIFIED DIMENSIONS ARE IN INCHES TOLERANCES ARE: | |  | | GRISWOLD PUMP COMPANY 22960 VAN BUREN STREET GRAND TERRACE, CA 92313-9697 PHONE: (909) 943-2022 / (925) 226-5355 WWW.GRISWOLDPUMP.COM | |
| DECIMALS .XX ± - | | TITLE 10 X 8 - 13 A100 ANSI PEO, XL PF | | DRAWN BY R. Schwartz DATE 01/26/17 ASSY. NO. _____ | |
| .XXX ± - | | CHECKED BY R. Beach DATE 1/26/17 DRAWING NO. _____ | | REV. _____ | |
| ANGLES ± - | | APPROVED BY B. Backman DATE 1/26/17 | | LG0793 A | |
| SCALE 1/8 | SHEET 1 OF 1 | | | | |

THIS DOCUMENT AND ITS CONTENTS ARE PROPRIETARY TO GRISWOLD PUMP ANY REPRODUCTION, DISCLOSURE OR USE OF THIS DOCUMENT IS EXPRESSLY PROHIBITED EXCEPT AS OTHERWISE AGREED TO IN WRITING.