

| REV | DESCRIPTION                                   |
|-----|---|
| A   | RELEASED INTO PRODUCTION<br>SEE ECN #GRT00022 |

NOTES: UNLESS OTHERWISE SPECIFIED

1. DIMENSIONS AND TOLERANCES PER ASME Y14.5M-1994.
2. \* INDICATES DIMENSIONS AND/OR FEATURES MODIFIED ON CURRENT REV LEVEL.

3. MINIMUM DIMENSION FOR REPACKING.

THIS DRAWING DOES NOT SHOW DETAILS OF ALL OPTIONS AND ACCESSORIES

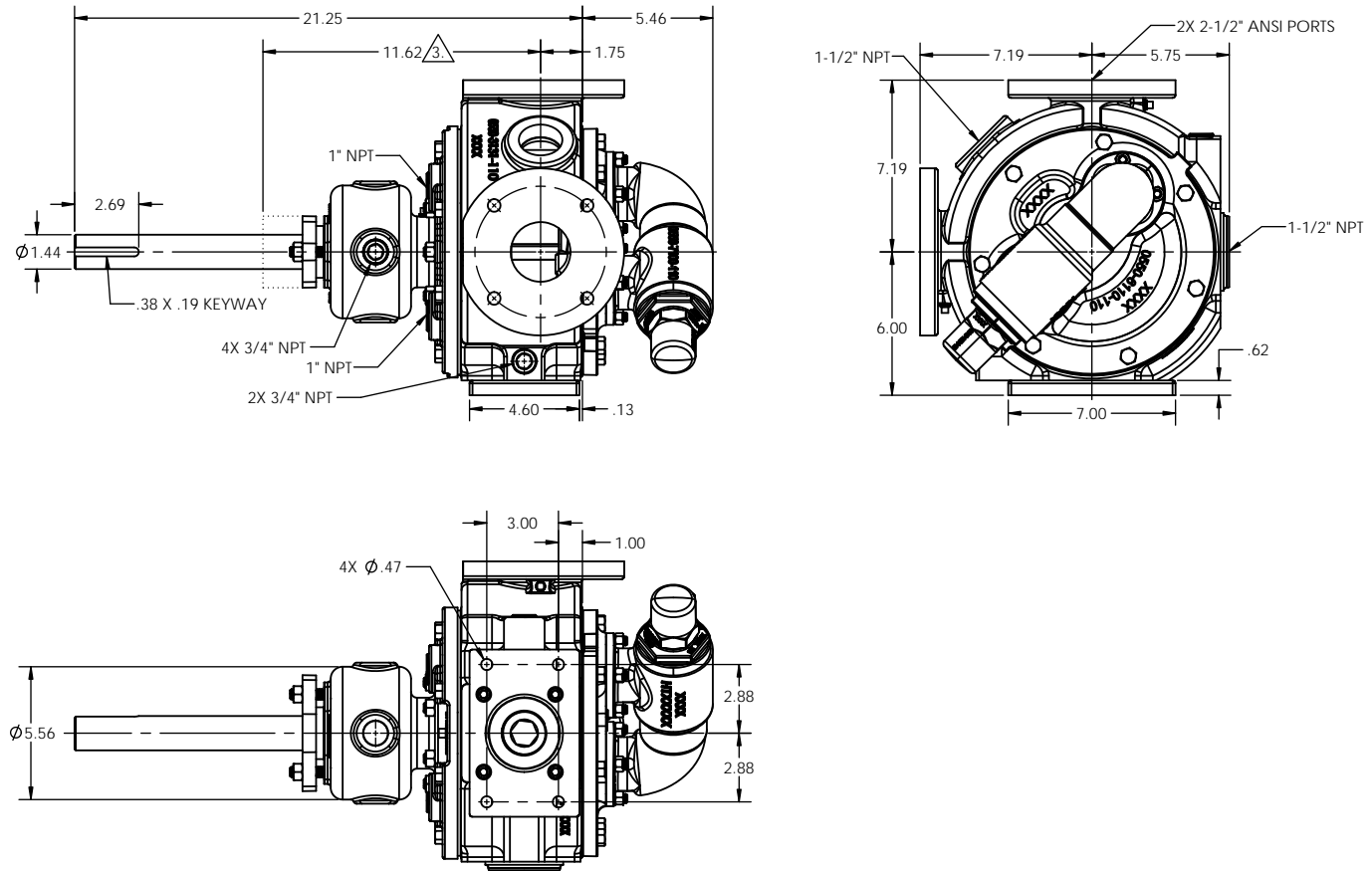

THIS DOCUMENT CONTAINS PROPRIETARY INFORMATION OF PSG - A DOVER COMPANY. ITS RECEIPT AND POSSESSION DO NOT CONVEY ANY RIGHTS TO REPRODUCE OR DISCLOSE ITS CONTENTS OR TO MANUFACTURE USE OR SELL ANYTHING IT MAY DESCRIBE. THIS DOCUMENT IS SUBJECT TO RETURN UPON REQUEST. REPRODUCTION, DISCLOSURE OR USE OF THIS DOCUMENT WITHOUT THE WRITTEN AUTHORIZATION OF DOVER CORPORATION IS STRICTLY FORBIDDEN.

**DO NOT SCALE DRAWING**  
UNLESS OTHERWISE SPECIFIED  
DIMENSIONS ARE IN INCHES  
TOLERANCES ARE:  
DECIMALS .XX ± -  
.XXX ± -  
ANGLES ± -

THIRD ANGLE PROJECTION

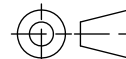

|                    |                    |
|--------------------|--------------------|
| DRAWN BY<br>CJL    | DATE<br>2017-12-20 |
| APPROVED BY<br>BKW | DATE<br>2018-01-22 |

|   |                       |  |  |
|---|-----------------------|--|--|
|   |                       | ENVIROGEAR® PUMPS<br>22069 VAN BUREN STREET<br>GRAND TERRACE, CA 92313 USA<br>909 422-1731<br>WWW.ENVIROGEARPUMP.COM |  |
| TITLE<br>PUMP ASSEMBLY, DIMENSIONAL<br>V2-55, NON-JK HEAD, NON-JK PRV |                       |  |  |
| SIZE<br>C   | DRAWING NO.<br>LM0062 | REV.<br>A  |  |
| SCALE<br>1:4  | SHEET<br>1            | 1 OF 1   |  |