

NOTES: UNLESS OTHERWISE SPECIFIED

1. DIMENSIONS AND TOLERANCES PER ASME Y14.5M-1994.
2. * INDICATES DIMENSIONS AND/OR FEATURES MODIFIED ON CURRENT REVISION LEVEL.
3. ALL DIMENSIONS ARE FOR REFERENCE ONLY.
4. DIMENSIONS IN [] ARE MILLIMETERS.
5. PORT ORIENTATION SHOWN MAY BE DIFFERENT THAN THE SELECTED ORIENTATION.
6. THIS DRAWING DOES NOT SHOW DETAILS OF ALL OPTIONS AND ACCESSORIES.
7. AVAILABLE WITH ANSI 150# RAISED FACE COMPATIBLE FLANGE. SEE FLANGE CHART FOR DIMENSIONS.

FLANGE DIMENSIONS			
3" ANSI 150# COMPATIBLE			
NOMINAL PIPE SIZE	BOLT CIRCLE DIA	NO OF BOLTS	BOLT HOLE SIZE
3.00 [76.2]	6.00 [152.4]	4	0.625-11 UNC-2B

REV.	DESCRIPTION	BY	CHK.	APP.	DATE
A	RELEASED INTO PRODUCTION SEE ECN #E00122	-	-	-	-
B	SEE ECN #E00195	C.L.	R.A.	J.F.	02/21/14
C	SEE ECN #E00284	HARI	C.L.	B.W.	10/18/16

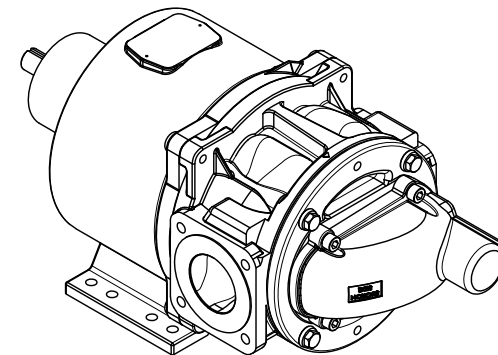
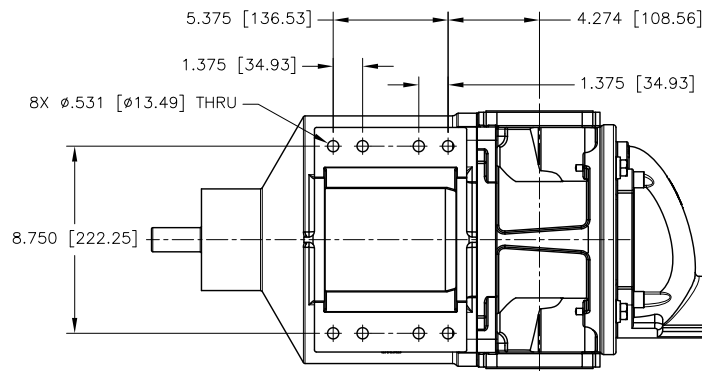
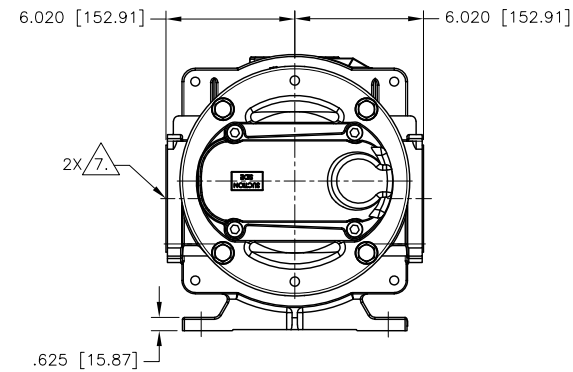
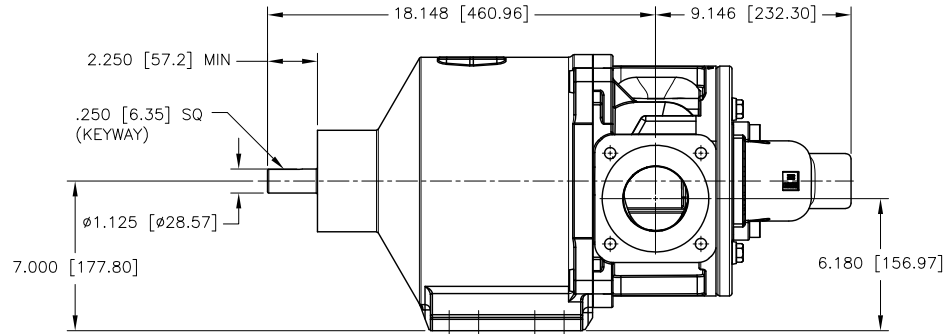

THIS DOCUMENT AND ITS CONTENTS ARE PROPRIETARY TO ENVIROGEAR INTERNAL GEAR PUMP. ANY REPRODUCTION, DISCLOSURE OR USE OF THIS DOCUMENT IS EXPRESSLY PROHIBITED EXCEPT AS OTHERWISE AGREED TO IN WRITING.

DO NOT SCALE DRAWING UNLESS OTHERWISE SPECIFIED DIMENSIONS ARE IN INCHES TOLERANCES ARE:				EnviroGear® Internal Gear Pumps 22069 VAN BUREN STREET GRAND TERRACE, CA 92313-5607 909-424-1731 WWW.ENVIROGEARPUMP.COM	
DECIMALS .XX ± -		TITLE E1-55/69/82, 3" ANSI, 180 DEG, W/PRV, SM SHAFT DIMENSIONAL DRAWING		DRAWN BY C. LEOPOLD DATE 01/24/13 ASSY. NO.	
ANGLES ± -		CHECKED BY R. ANDRADE DATE 02/13/13 DRAWING NO.		REV. C	
SCALE 1/4	SHEET 1 OF 1	APPROVED BY N. WINSOR DATE 02/13/13		LE0020	