

EBSRAY PUMPS

INSTALLATION, OPERATION AND MAINTENANCE INSTRUCTIONS

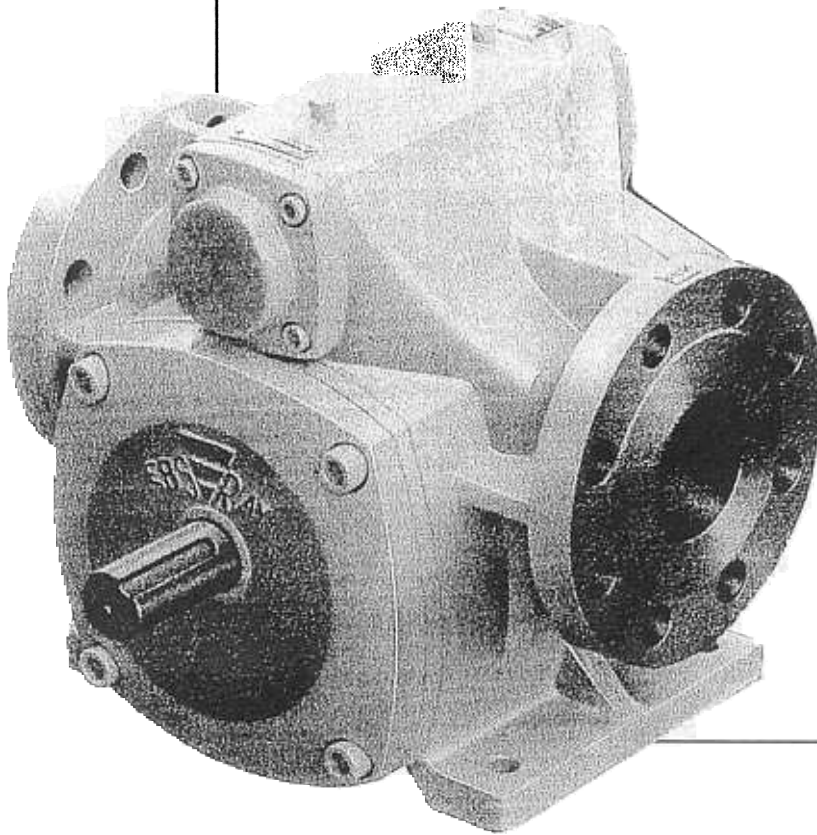

V Series Model V20 Types 25, 26 & 29



Quality
Endorsed
Company
ISO 9001
Lic 3332
Standards Australia

EBSRAY PUMPS PTY. LTD ACN 000 061 003
628 Pittwater rd
Brookvale NSW 2100
AUSTRALIA
Ph: (02) 9905 0234
Fax (02) 9938 3825



CONTENTS

SECTION 1 - GENERAL	3
INTRODUCTION	3
1.1 CAUTION	3
1.2 WARNING	3
1.3 TRANSPORTATION AND PACKING	3
1.4 INSPECTION ON RECEIPT	3
1.5 HANDLING	3
SECTION 2 - INSTALLATION	3
2.1 LOCATION	3
2.2 FOUNDATIONS	3
2.3 PUMP PIPING CONNECTIONS	3
2.4 STRAINER PROTECTION	4
2.5 ALIGNMENT	4
SECTION 3 - OPERATION	4
3.1 DESCRIPTION	4
3.2 LUBRICATION	4
3.3 START-UP CHECKLIST	4
3.4 OPERATIONAL CHECKS	4
SECTION 4 - MAINTENANCE	5
4.1 SPARE PARTS	5
4.2 PREPARATION FOR DISASSEMBLY	5
4.3 DISASSEMBLY	5
Part 1 - Bypass Valve	5
Part 2 - Pump	5
4.4 INSPECTION	6
4.5 REASSEMBLY - PRELIMINARY	7
Part 1- Pump :	7
4.6 REASSEMBLY Part 1 - Pump	7
Part 2 - Bypass Valve	9
SECTION 5 - INSTRUCTIONS FOR REVERSING DIRECTION OF FLOW	10
SECTION 6 - TROUBLE SHOOTING	11
6.1 FAILURE TO DELIVER LIQUID	11
6.2 LOW OUTPUT	11
6.3 EXCESSIVE POWER CONSUMPTION	11
6.4 PUMP IS NOISY	11
6.5 LEAKAGE	11
SECTION 7 - PARTS DESIGNATION	12

DETERMINATION OF MAINTENANCE REQUIREMENTS

EBSRAY V Series pumps are used for a wide range of applications and as such, maintenance requirements will vary between applications. Under ideal/good operating conditions, providing pump is not run dry, inspection of vanes is recommended at approximately 2000 operating hour intervals. During this inspection, check bearings and other components for wear or damage. Under less favourable conditions, inspect more frequently dependant on severity. Any reduction in performance (either flow, differential pressure or efficiency) will indicate either a system or pumpset or pump problem. Regular observation during operation will quickly identify symptoms such as leaking seals. Development of unusual noises or vibration will indicate system/hydraulic problems, excessive wear, mechanical damage or foreign objects in the pump.

SECTION 1 - GENERAL

INTRODUCTION

This publication is intended to assist those involved with the installation, operation and maintenance of EBSRAY Models V20 Types 25, 26 and 29 Rotary Sliding Vane Pumps. The design, materials and workmanship incorporated in the manufacture of EBSRAY pumps make them capable of reliable operation over a long working life. Correct installation is essential. Service life is enhanced by periodic inspection and careful maintenance.

1.1 CAUTION

INSTALLATION AND SERVICING OF THIS EQUIPMENT SHOULD BE PERFORMED BY QUALIFIED COMPETENT PERSONNEL IN ACCORDANCE WITH RELEVANT STATUTORY REGULATIONS OR CODES, IN CONJUNCTION WITH THESE INSTRUCTIONS.

When the equipment supplied utilises components other than those manufactured by EBSRAY e.g. couplings, speed reducers, electric motors etc, reference should be made to the original manufacturer's data before installation or servicing is commenced. Failure to observe these details may void the warranty.

1.2 WARNING

The pump must be operated within the original selected design parameters of product, viscosity, temperature, speed and pressure. Should any change

be contemplated, please confer with EBSRAY in order to verify the suitability of such a change.

1.3 TRANSPORTATION AND PACKING

Standard domestic packing is suitable for shipment in covered transports. Ports must be sealed to exclude ingress of solids. When received on site the pump should be stored in a dry covered area. If storage is required for other than a short period prior to installation, special preservatives and protective wrappings will be required.

1.4 INSPECTION ON RECEIPT

On receipt of equipment, check all items against the dispatch documents and inspect for damage. Any damage or shortage incurred during transit should be noted on the packing note and on both your own and the carrier's copy of the consignment note and a claim should be made immediately on the transport company. Should a shortage be evident on receipt, notify EBSRAY immediately giving full details and packing note number.

1.5 HANDLING

Care should be used in moving pumps. A sling should be placed under or around a bare shaft pump to minimise stress on the shaft or pump flanges. Baseplate mounted units should be lifted from under the baseplate below both the pump and driver ensuring compliance with the relevant lifting codes.

SECTION 2 - INSTALLATION

2.1 LOCATION

The pumping unit should be placed as close as practicable to the source of supply remembering to keep within the NPSH requirement of the pump. Ensure floor area and headroom allotted are sufficient for inspection and maintenance. Allow sufficient space and ventilation for motor cooling requirements. Be sure to allow for crane or hoist access if required.

For vertically mounted pumps (DRIVE SHAFT VERTICAL) the plug in the inspection end bearing housing cover should be removed. See addendum sheet for more information.

2.2 FOUNDATIONS

Baseplate units should be accurately installed. When on a concrete foundation, ensure that it has been poured on a solid footing. NOTE: Position foundation bolts to match baseplate foundation plan.

2.3 PUMP PIPING CONNECTIONS

All piping should be supported independently of and line up accurately with the pump ports. NEVER DRAW PIPING INTO PLACE BY USE OF FORCE AT THE PORT CONNECTIONS OF THE PUMP.

2.4 STRAINER PROTECTION

The pump suction should always be protected by an efficient suction strainer of adequate size to accommodate the liquid viscosity conditions without causing excessive suction resistance.

2.5 ALIGNMENT

Alignment of the pump and driver is of extreme importance for trouble free mechanical operation. Baseplate mounted units are accurately aligned at the factory. To ensure this has been maintained during transit, alignment **MUST BE** checked once before startup and again after the unit has been run under actual operating conditions. **NOTE:** The following procedures are typical only and reference should be made to data for specific coupling types.

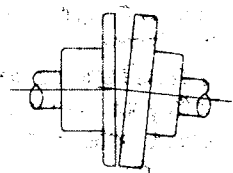

Figure 3

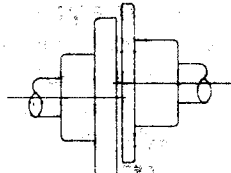

Figure 4

ANGULAR MISALIGNMENT as shown in Fig.1 should be corrected before eccentricity. Refer Fig.3; use feeler gauge reading at 90° intervals, the amount of correction necessary can be easily determined to bring shaft axes in line.

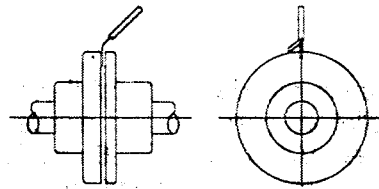

Figure 5

Misalignment due to ECCENTRICITY as shown in Fig.2 can now be corrected. Refer Fig.4; adjustment by use of shims under the driver or pump will effectively correct error in the vertical plane. Movement of one of the ends horizontally will correct error in the horizontal plane. **NOTE:** If both coupling halves are of identical diameter, concentricity may be checked with a straight edge at 90° intervals.

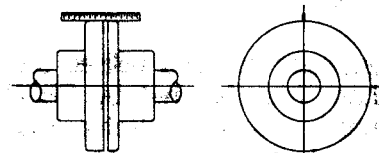

Figure 6

SECTION 3 - OPERATION

3.1 DESCRIPTION

The EBSRAY Model V20, Types 25, 26 and 29 are positive displacement sliding vane pumps, primarily intended for the transfer of low to medium viscosity liquids. In each type the Rotor/Shaft assembly rotates within a cam form Liner and between two replaceable wearplates. Two balanced mechanical seals, located outside the wearplates, isolate the Drive End and Inspection End Bearings from the pumpage. These sealed, grease packed ball bearings provide positive axial positioning of the pump rotor. A lip seal is fitted to the Drive End Cover to minimise the ingress of dust/dirt along the shaft. The pump is protected from excessive pressure rise by a standard balanced type bypass valve in type 26 and type 29. The type 25 pump has the bypass blanked off and therefore offers no bypass protection. As an option with all types, the liquid flow can be reversed. See Section V.

3.2 LUBRICATION

No 'in service' lubrication is required on EBSRAY's Model V20 Types 25, 26 and 29.

3.3 START-UP CHECKLIST

Direction of rotation **NOTE Disengage coupling before testing motor rotation**

Alignment of couplings

Free rotation of shaft

Do not start pump against closed discharge valve or with suction valve throttled.

DO NOT RUN PUMP DRY

3.4 OPERATIONAL CHECKS

Inspect pump frequently during the first few hours of operation for such conditions as excessive heating of bearings, vibration or unusual noises etc.

SECTION 4 - MAINTENANCE

PRIOR TO ANY DISASSEMBLY OR SERVICE VERIFY THAT ALL REQUIREMENTS OF STATUTORY REGULATIONS OR CODES ARE MET AND THAT SPECIFIC SITE REQUIREMENTS ETC ARE SATISFIED.

Some inspections and maintenance tasks, can be performed with the pump 'in line', so long as complete isolation, depressurising and purging procedures have been completed. However for major maintenance, it is recommended that the pump be removed from the installation.

The following instructions regarding disassembly/reassembly are relative to major maintenance.

4.1 SPARE PARTS

1. When ordering spare parts, to ensure a minimum of delay and correct replacement to original specification, always quote the pump Serial Number which is located on the nameplate of the pump.
2. Advise the name, Cat# and quantity required. Refer to Drawing No. CMP054
3. Advise complete delivery instructions, transportation, etc.

4.2 PREPARATION FOR DISASSEMBLY

1. Obtain the appropriate Work Permit if required.
2. Isolate the pump from liquids in suction and discharge lines, depressurise and purge out any toxic, flammable, corrosive or air hardening liquids.
3. Isolate power supply to motor.
4. Note pump and bypass valve orientation relative to direction of pump rotation.
5. Disconnect porting connections.
6. Remove pump from installation.

4.3 DISASSEMBLY

Note: Items required to aid Disassembly/Reassembly

- a) Four 1/2" B.S.W. x 25mm setscrews

- b) Two 1/4" B.S.W. x 75mm bolts
- c) Four 5/16" B.S.W. x 50mm setscrews

CAUTION: TAKE CARE NOT TO DAMAGE COMPONENTS BY PRISING OR LEVERING IN ORDER TO RELEASE FITS.

Part 1 - Bypass Valve

1. Unlock locknut, remove adjusting screw, locknut and spring washer from bypass valve cover.
2. Remove bypass valve cover and 'O' ring together with valve spring and retaining washer with its 'O'ring.
3. Remove valve spring, retaining washer and 'O'rings from cover.
4. Remove valve from cartridge.

NOTE: Valve cartridge is factory fitted and should not need removal.

Part 2 - Pump

1. Remove pump coupling half from shaft.
2. Remove inspection end bearing housing cover.
3. Release bearing clamp bolt.
4. Withdraw inspection end bearing housing complete with ball bearing, spacer, stationary seal face and 'O'ring, by extracting with two 5/16" B.S.W x 2" setscrews in tappings provided.
5. Remove body 'O'ring.
6. Remove stationary seal face and 'O'ring from housing.
7. Remove ball bearing from housing.
8. Release two grubscrews on mechanical seal sleeve at least 1-1/2 turns.
Note: Grubscrews lock into a location groove in the shaft and must be backed off to minimise the possibility of scoring shaft upon withdrawal of seal sleeve.
9. Withdraw rotating seal face and seal sleeve assembly.

10. Withdraw inspection end wearplate complete with location pin, using two 1/4" B.S.W. x 75mm bolts in tappings provided.

CAUTION: Do not remove vanes at this stage as pushrods will slide out and catch in liner porting.

11. Remove drive end bearing housing cover, complete with lip seal.
12. Remove lip seal from drive end bearing housing cover.
13. Withdraw pump drive end assembly, comprising bearing housing complete with bearing, spacer, mechanical seal and rotor/shaft assemblies, by extracting with two 5/16" B.S.W. x 2" set screws in tappings provided.

NOTE: When Removing pump drive end assembly cradle vanes in rotor. Note orientation of vanes in relation to pump rotation (Refer Fig. 6) then remove vanes and pushrods from rotor.

14. Release bearing clamp bolt.
15. Using a suitable puller withdraw drive end bearing housing and 'O'ring, complete with ball bearing, spacer and stationary seal face from shaft.

Note: Mechanical seal is captive between wearplate and bearing housing and locked to shaft.

16. Remove body 'O'ring.
17. Remove stationary seal face, spacer and 'O'ring from housing.
18. Remove ball bearing from housing.
19. Release two grubscrews on mechanical seal sleeve at least 1-1/2 turns.

Note: Ensure grubscrews clear shaft as before. (Refer step 8)

20. Withdraw rotating seal face and seal sleeve assembly.
21. Remove drive end wearplate complete with location pin.
22. If required remove liner from body.

4.4 INSPECTION

1. Inspect rotor/shaft assembly and liner. If damage or excessive wear is evident, it is recommended to replace both components.

Note: The Rotor is a shrink fit on the Shaft and is pinned for positive axial location.

2. Inspect vanes for wear or damage Ref Table I.
3. Inspect vane pushrods for wear, damage and straightness. Replace as required
4. Inspect both mechanical seals. Replace worn or damaged components.
5. Inspect both wearplates and spacers for damage or excessive wear. Replace as required. **Note:** Wearplates can be reversed.
6. Inspect bypass valve assembly and components for wear or damage. Replace or refurbish as required.
7. It is recommended that all 'O' Rings and the lip seal be replaced at every overhaul.
8. Inspect both ball bearings for wear. It is recommended on major overhauls that ball bearings be replaced.

TABLE I

STANDARD GENERAL CLEARANCES AND SIZES FOR TEMPERATURES 0°- 100°C (All dimensions are in millimetres)

Radial rotor to liner clearance, measured at 12 o'clock position	0.02 - 0.04 mm
Total axial clearance, liner minus rotor length measured along axis	0.16 - 0.25 mm
Total vane clearance, liner length minus vane length	0.16 - 0.25 mm
Standard vane height	26.95 - 27.45 mm
Maximum wear on vane height	2.0 mm

Notes:

1. Dimensions stated are design parameters.
2. Efficient suction and discharge performance are achieved when the pump is maintained within these dimensions, however adequate performance may still be achieved with clearances and dimensions outside those stated if application parameters allow.
3. If installing new vanes or liner, check their lengths to comply with the clearances as stated.

4.5 REASSEMBLY - PRELIMINARY

(Refer Drawing No.CMP054)

1. Ensure all parts are clean and free from sharp edges, burrs etc.
2. Lightly smear all 'O'rings and lapped faces of mechanical seals with a compatible good quality lubricant before assembling.
3. Ensure correct orientation of components:

Bypass valve:

For clockwise pump rotation, adjusting screw position is opposite drive end.

For anti-clockwise pump rotation, adjusting screw position is at drive end.

4. Lap bypass valve into valve seat using 1/4" B.S.W. x 100mm bolt and locknut. Ensure no residue remains on components after lapping.

Part 1 Pump :

5. Fit location pin to each wearplate so that an equal length protrudes from each side.
6. Assemble both mechanical seals' rotating seal faces to seal sleeves as follows:
 - (a) Fit two 'O'rings to each seal sleeve.
 - (b) Place a dab of grease on each of the six springs and fit into the locating holes in the seal sleeve.
 - (c) Position the rotating seal face on the seal sleeve, ensuring the ends of the six springs locate in the mating holes in the seal face and the three drive pins locate correctly.
 - (d) Check that the rotating seal face is free to

follow axially by spring pressure when fitted to the shaft, by compressing the seal sleeve and rotating seal face by hand.

7. Press fit lip seal into drive end cover ensuring the sealing lip faces inwards.
8. To facilitate centralising of the rotor between the wearplates, soft paper shims (i.e. tissue paper) 0.10mm thick, may be fitted against the ends of the rotor.

4.6 REASSEMBLY Part 1 - Pump

1. Place rotor/shaft assembly on workbench and support so that shaft is vertical with drive end facing upwards.
2. Fit 0.1mm paper shims on shaft against rotor.
3. Position wearplate, fitted with location pin onto shaft above rotor.
4. Apply a medium strength thread locking adhesive to both seal grub screws and position in seal sleeve.
5. Push seal sub-assembly over drive end of shaft, locating so that grub screws will engage the shaft location groove. Lock grub screws onto shaft.
6. Fit 'O'ring to stationary seal face and fit this assembly into drive end bearing housing.

CAUTION: TAKE CARE NOT TO DAMAGE CARBON SEAT.

7. Carefully position drive end bearing housing with seal seat over end of shaft, so that location pin in wearplate engages locating hole in Bearing housing.

CAUTION: CARE MUST BE TAKEN NOT TO DAMAGE MECHANICAL SEAL FACES.

8. Fit spacer to shaft and locate against shoulder, with chamfer facing inwards (towards rotor).
9. Ensure bearing clamp bolt assembly is in position.
10. Apply Loctite 601 (or equivalent) to the I.D. of the inner and O.D. of the outer bearing rings. NOTE: Degrease surfaces in contact with Loctite. Fit bearing into housing via pressure applied to inner ring of ballrace until it locates against spacer.

11. Lock bearing clamp bolt assembly.
12. Fit liner to body with bleed hole to pump discharge and thick section to bottom of pump. Refer Fig. 5. Leave liner protruding about 10mm from drive end.
13. Locate pump body upside down on work bench and support horizontally in this position. (i.e. with bypass valve body below pump foot.)

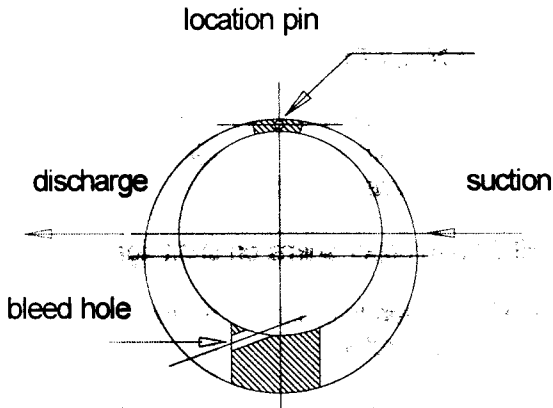

Figure 5

14. Fit 'O'ring to bearing housing.
15. Fit three vane pushrods and six vanes to rotor as follows:

Note: THE HYDRAULIC RELIEF SLOTS IN VANES MUST LEAD THE DIRECTION OF ROTATION AND VANE PLATES MUST FACE THE PUSHRODS. (Refer Fig. 6)

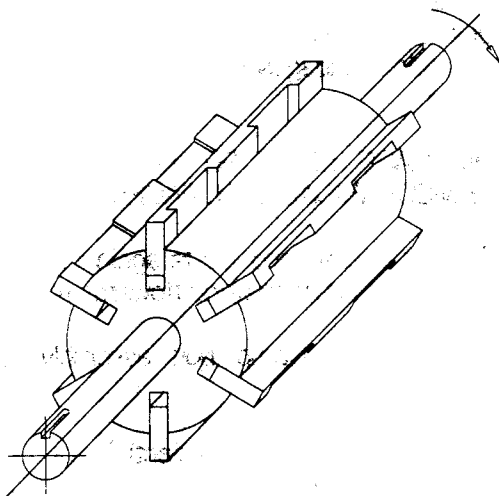

Figure 6

With the Shaft in the horizontal insert three vanes to top slots of rotor. Turn rotor 180° whilst supporting vanes in the rotor. Now insert three pushrods followed by the other three vanes.

16. Cradling by hand the vanes in the rotor, insert the pump drive end assembly into the protruding end of the liner. Once the vanes are partially engaged in the liner bore, rotate bearing housing to ensure location pin in wearplate will engage location hole in liner and push assembly home.
17. Temporarily fasten bearing housing in position using two 1/2" B.S.W. x 25mm setscrews.
18. Fit 0.01mm paper shims to I.E. of shaft against rotor.
19. Install inspection end wearplate so that location pin engages location pin hole in liner, facilitated by using two 1/4" B.S.W. x 75mm bolts in tappings provided. Remove bolts.
20. Apply a medium strength thread locking adhesive to both seal grub screws and position in seal sleeve.
21. Push seal sub-assembly over shaft, locating so that grub screws will engage the shaft location groove. lock grub screws onto shaft.
22. Fit 'O' Ring to stationary seal face and fit this assembly into inspection end bearing housing . CAUTION: TAKE CARE NOT TO DAMAGE CARBON FACE.
23. Fit 'O'ring to inspection end bearing housing.
24. Carefully position inspection end bearing housing with seal face over end of shaft, so that location pin in wearplate engages locating hole in bearing housing. CAUTION: CARE MUST BE TAKEN NOT TO DAMAGE MECHANICAL SEAL FACES.
25. Temporarily fasten bearing housing in position using two 1/2" B.S.W. x 1" setscrews.
26. Fit spacer to shaft and locate against shoulder, with chamfer facing inwards (towards rotor).
27. Ensure bearing clamp bolt assembly is in position.
28. Apply Loctite 601 (or equivalent) to the I.D. of the inner and O.D. of the outer bearing rings. NOTE: Degrease surfaces in contact with

Loctite. Fit bearing into housing via pressure applied to inner ring of ballrace until it locates against spacer. Ensure rotor is centralised.

29. Lock bearing clamp bolt assembly.
30. Rotate shaft and check pump for binding.
31. Remove the two 1/2" B.S.W. setscrews from inspection end bearing housing and fit cover to housing.
32. Remove the two 1/2" B.S.W. setscrews from drive end bearing housing and fit drive end cover to bearing housing, taking care not to damage lip seal on keyway edges.

NOTE: During procedures 31 & 32 ensure that drainage slots in covers are free of any obstruction. For vertically mounted pumps (DRIVE SHAFT UP) the plug in the inspection end bearing housing cover should be removed.

33. Check shaft for freedom of rotation.
34. Turn pump over to locate on base.
35. Refit pump coupling Half.

Part 2-Bypass Valve

Note: Ensure correct orientation with reference to pump rotation.

1. Fit valve cartridge to body if removed.
2. Lock valve cartridge in place, by grub screw using thread locking adhesive. Fit fibre washer and acorn nut.
3. Fit previously lapped valve to valve cartridge.
4. Fit retaining washer 'O'ring and cover 'O'ring.
5. Lubricate bore and slide retaining washer over 'O'ring onto cover and check for freedom of movement.
6. Position spring over retaining washer.
7. Fit cover assembly to body so that end of spring locates on top of valve.
8. Fit adjusting screw with locknut and spring washer to cover.

Note: The bypass valve will require setting when the pump is recommissioned.

For increased bypass pressure, rotate adjusting screw in clockwise direction (i.e., screw in). For decreased bypass pressure, rotate adjusting screw anticlockwise (i.e., screw out). Always lock locknut after any adjustment is made and rewire seal if required.

SECTION 5 - INSTRUCTIONS FOR REVERSING DIRECTION OF FLOW

The Ebsray Model V20 pump has its direction of rotation handed upon assembly (either clockwise or anti-clockwise when looking at the shaft from the shaft end which is the drive end). The flow path of the liquid is indicated by cast arrows on the sides of each port.

CLOCKWISE ROTATION PUMP:

- a. Inlet RH side, Outlet LH side.
- b. Bypass valve adjusting screw located on pump opposite drive end.

ANTI-CLOCKWISE PUMP:

- a. Inlet LH side, Outlet RH side
- b. Bypass valve adjusting screw located on pump at drive end.

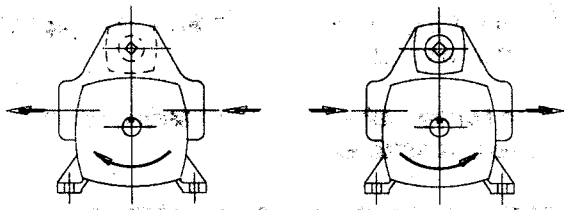

Figure 7 V2 V4

To reverse the direction of rotation four conditions must be met :

1. The bypass valve must be turned 180° in order to maintain bypass protection in the new direction. i.e. adjusting screw must be at the opposite end to where it was originally relative to the drive shaft.
2. The hydraulic relief grooves in the vanes must lead the direction of rotation.
3. The cast "s" on the liner must be towards the suction port (the port with the cast arrow pointing inward)
4. The cast arrows indicating flow path must be in accordance with the above description.

Procedure for Reversing Direction of Pump:

- a. Remove inspection end housing from body.
- b. Remove drive end housing from body. (Note D.E. housing consists of a complete assembly, including rotor/shaft, vanes and cover.
- c. Rotate body through 180°. This will now orientate both the liner and the bypass valve adjusting screw opposite their original positions.
- d. Reverse vanes in their respective rotor slots in order to have the relief grooves leading the new direction of rotation.

Reassemble the removed components taking care not to damage the 'O'ring seals. The complete drive end housing assembly should be fitted first, followed by the inspection end housing. Care should be exercised to ensure the Location Pins in the Covers engage in their holes before tightening the cover bolts. The pump shaft should now rotate freely. Should this not occur, check for binding of components and/or foreign matter in pump.

Should further assistance or guidance be required please contact your supplier or EBSRAY PUMPS direct.

SECTION 6 - TROUBLE SHOOTING

6.1 FAILURE TO DELIVER LIQUID

1. Incorrect direction of rotation.
2. Suction filter/strainer blocked or leaking air.
3. Liquid too viscous.
4. No liquid in tank.
5. High static discharge on pump combined with air/vapour in suction pipe.
6. Valves closed or air leaks in suction system.
7. Excess internal clearances.
8. Pump vapour locked

6.2 LOW OUTPUT

1. Pump speed too low.
2. Cavitation or vaporisation on suction side of pump.
3. Obstruction in suction or discharge pipe.
4. Air leakage in suction pipes or fittings.
5. Bypass valve pressure setting too low - increase pressure by screwing in adjusting screw. DO NOT exceed system design pressure or overload driver.
6. System differential pressure higher than specified duty point.
7. Viscosity of liquid lower than specified duty point.
8. Pump parts worn - have pump reconditioned or replace worn parts.

6.3 EXCESSIVE POWER CONSUMPTION

1. Obstruction in discharge line.
2. Pump operating outside the specified duty point (i.e. high differential pressure, viscosity and/or speed)
3. Rotating parts binding - disassemble pump and inspect.
4. Misalignment between pump and driver - check coupling and realign as required.
5. Inherent pipe stresses causing distortion of

pump and casing - rectify and realign before reassembly.

6. Bearings worn - inspect and replace as required.

6.4 PUMP IS NOISY

1. Air leakage in suction piping.
2. Cavitation due to insufficient NPSH available i.e. suction conditions extreme - reduce suction losses.
3. Pump running dry - remove blockages in suction line/strainer.
4. Pump and driver misaligned - check coupling and realign as required.
5. Rotating elements binding or broken - disassemble and inspect.
6. Bearings worn - inspect and replace as required.

6.5 LEAKAGE

1. From covers and flanges:
 - a) Set screws not tight - retighten.
 - b) Damaged 'O' ring seals or gaskets - replace.
 - c) Check for thermal expansion of product when locked between valves either side of pump. Remove hydraulic lock potential.
2. From mechanical seal: (as evidenced by product leaking from 6 o'clock position drain hole between Bearing Housing and Bearing Housing Cover)
 - a) Mechanical seals incorrectly installed, worn or damaged - replace.
 - b) Misalignment between pump and driver causing excessive shaft distortion - check coupling and realign as required.
 - c) Worn or damaged shaft in seal zone - replace rotor/shaft.
 - d) Excess system pressure - check for obstructions in discharge line and check for thermal expansion of product when locked between valves either side of pump. Remove hydraulic lock potential.

SECTION 7 - PARTS DESIGNATION

EBSRAY MODELS: V20 Types 25, 26 and 29 Rotary Sliding Vane pumps.

REFER TO DRAWING N°: CMP054

Cat#	Description	Qty	Cat#	Description	Qty
100	Body	1	408	Balanced Bypass Valve	1
101	Liner	1	412	Grubscrew Bypass Valve Cartridge	1
102	Rotor/Shaft assembly	1	413	Acorn Nut - Bypass Cartridge	1
107	Wearplate	2	414	Fibre Washer - Acorn Nut	1
110	Location pin - Liner/Wearplate	2	415	Spring -Bypass Valve	1
111	Vane	6	416	Retaining Washer - Bypass Valve Spring	1
115	Vane Pushrod	3	502	Seal Sleeve	2
200	Drive end Bearing Housing	1	503	stationary Seal Face	2
201	Drive end Bearing Housing Cover	1	504	Rotating Seal Face	2
204	Drive end Bearing	1	505	Spring - Mechanical Seal	12
205	Spacer - Drive end Bearing	1	508	'O'ring - Shaft	2
300	Inspection end Bearing Housing	1	509	'O'ring - Seal Sleeve	2
301	Inspection end Bearing Housing Cover	1	510	'O'ring - Stationary Seal Face	2
304	Inspection end Bearing	1	513	Lip Seal - Drive end Bearing Housing Cover	1
305	Spacer - Inspection end Bearing	1	515	'O'ring - Body	2
318	Drain Plug	1			
400	Cover - Bypass Valve	1	516	'O'ring - Bypass Valve Cover	2
401	Adjusting Screw - Bypass Valve	1	517	'O'ring - Bypass Valve Retaining Washer	1
402	Locknut - Bypass Valve Adjusting Screw	1	600	Bearing Clamp Bolt Assembly	2
407	Cartridge - Bypass Valve	1			

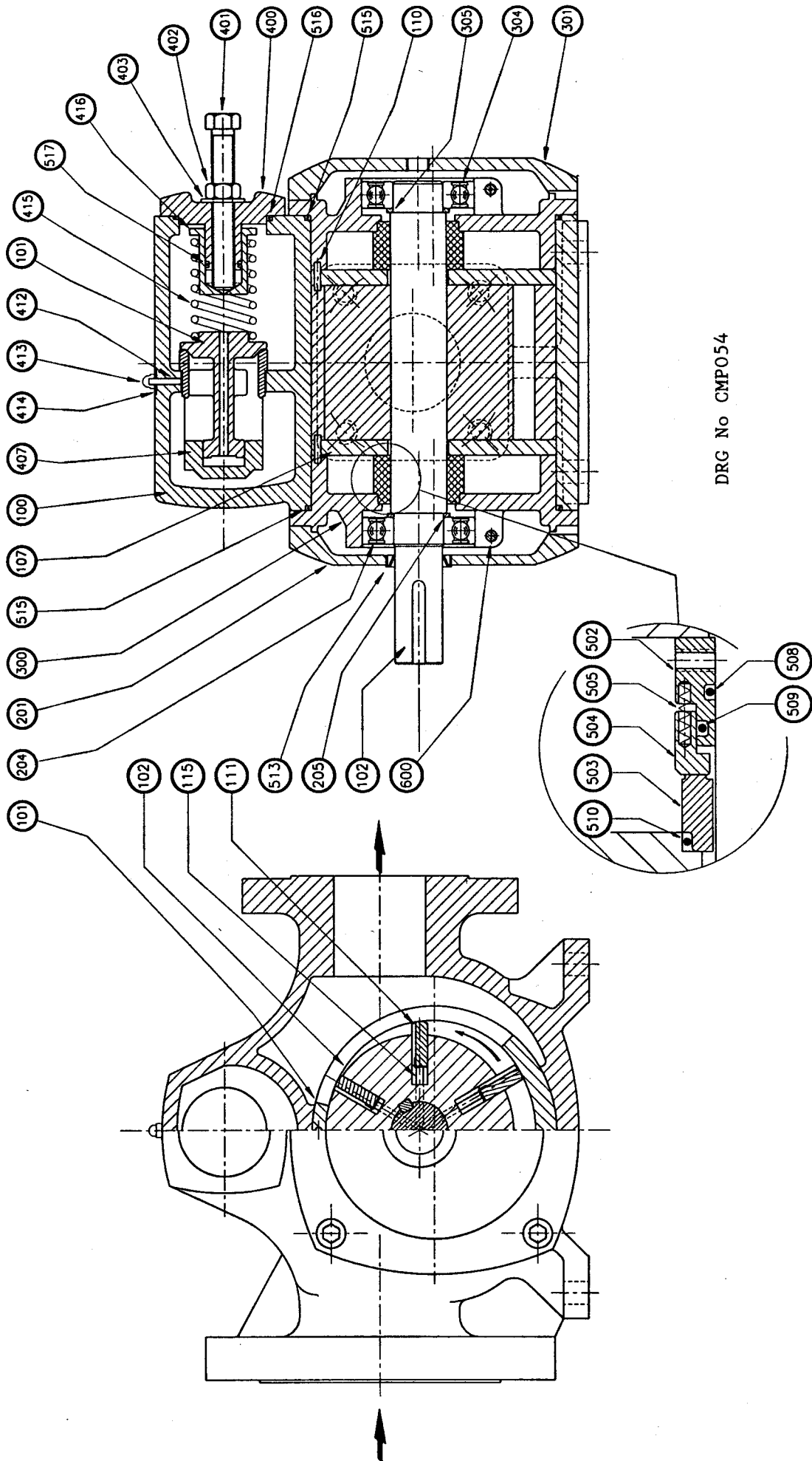

DRG No CMP054