

EBSRAY PUMPS

INSTALLATION, OPERATION & MAINTENANCE INSTRUCTIONS

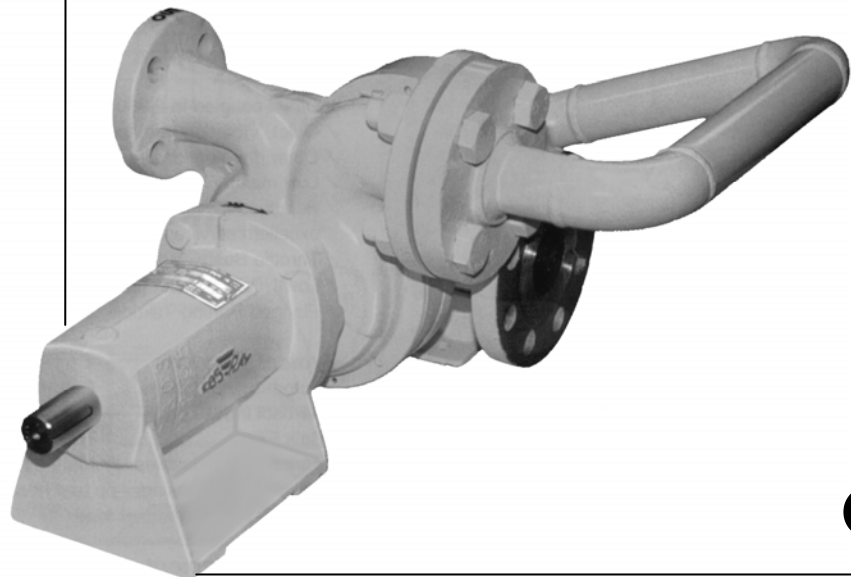

CE

R SERIES ***MODEL RB10 (50Hz and 60Hz)***

.... For LPG APPLICATIONS
Pumping from underground tanks

CONTENTS

SECTION 1 – GENERAL	4
1.1 INTRODUCTION.....	4
1.2 TRANSPORTATION, PACKING & STORAGE	4
1.3 RECEIVING INSPECTION.....	4
1.4 HANDLING.....	4
1.5 WARRANTY.....	4
SECTION 2 – SYSTEM DESCRIPTION	5
2.1 EBSRAY RB10 LPG PUMPING SYSTEM	5
2.2 BYPASS VALVE – EBSRAY #RV18-VRS19.....	5
2.3 NON-RETURN VALVE.....	5
SECTION 3 – INSTALLATION	6
3.1 LOCATION.....	6
3.2 COUPLING ALIGNMENT	6
3.3 FOUNDATIONS	6
3.4 PUMP PIPING CONNECTIONS	6
3.5 SYSTEM PIPING CONNECTIONS	6
3.5.1 Foot Valve (Non-Return Valve)	7
3.5.2 Pump Inlet Pipe	7
3.5.3 Pump Discharge Pipe.....	7
3.5.4 Bypass Valve.....	7
SECTION 4 – OPERATION	8
4.1 DESCRIPTION.....	8
4.2 LUBRICATION	8
4.3 PRE-STARTUP CHECKLIST	8
4.4 STARTUP PROCEDURE	8
4.5 PERIODIC INSPECTION	8
SECTION 5 – MAINTENANCE	9
5.1 PREPARATION FOR DISASSEMBLY	9
5.2 DISASSEMBLY	9
5.3 INSPECTION	9
5.4 SPARE PARTS	9
5.5 REASSEMBLY - PRELIMINARY.....	10
5.6 REASSEMBLY	10
SECTION 6 – PARTS DESIGNATION	11
SECTION 7 – TROUBLESHOOTING	12
APPENDIX A – TYPICAL INSTALLATION P&ID	15
APPENDIX B – SYSTEM PRE-STARTUP COMMISSIONING CHECKLIST	16
APPENDIX C – EBSRAY PUMP RUN LOG	17
APPENDIX D – DECLARATION OF CONFORMITY	18

EBS-RAY PUMPS Pty. Limited



628 Pittwater Road
Brookvale NSW 2100 Australia
Phone: (+612 9905 0234)
Fax: (+612 9938 3825)
www.ebsraypumps.com.au

or Contact Ebsray Representative:

IMPORTANT NOTES

1. This Publication is **TYPICAL ONLY** and only relates to the specifications of the minimum equipment required to ensure the optimum performance, maximum life and trouble-free operation of the Ebsray RB10 Pumpset and the Pumping System in general.
2. Products with the mandatory European CE mark affixed indicate conformity to the essential health and safety requirements via their applicable EU Directives (e.g. ATEX 94/09/EC, Machinery 98/37/EC etc). As certain specific products/equipment outlined in this Publication are CE marked (meaning the equipment has been assessed and supplied in conformity to those Directives), **STRICT ADHERENCE** with **ALL** the instructions and recommendations forms an essential part in maintaining the product/equipment's conformity. **Failure to comply with the instructions and recommendations contained in this Publication may void CE conformity.**
3. This Publication does **NOT** depict:
 - a) Ancillary required equipment related to the fabrication, installation and operation of the Pumpset e.g. miscellaneous flanges, fittings etc.
 - b) Required equipment unrelated to the Pumpset e.g. tank fill lines, vapour return lines, emergency shutdown systems etc.
 - c) The materials and method of fabrication and/or installation of the tank and required sub-systems.
4. It is the responsibility of the designer, fabricator and the installer of each actual tank and required sub-systems to ensure that:
 - a) The Ebsray specifications within this Publication and any other relevant Ebsray documents are **STRICTLY** adhered to.
 - b) Any variation (including use of equipment deemed "Equivalent") or addition to the Ebsray Specifications, as related to the Pumpset and Pumping System in general, meet Ebsray's minimum requirements.
 - c) All design, fabrication and installation of the tank and sub-systems is **STRICTLY** in accordance with all relevant National, State and Local Codes, Regulations, Standards and Directives.
5. Ebsray reserves the right to:
 - a) Withdraw or alter any or all of the Ebsray specifications within this Publication and any other relevant Ebsray documents without notification.
 - b) Determine the validity of any Warranty claims for Ebsray equipment based on the proper application of Ebsray supplied equipment by the way of adherence to the Ebsray specifications within this Publication and any other relevant Ebsray documents.

Terms used in this publication requiring special attention:

1.  **DANGER**
Non-compliance with requirements under this heading could create circumstances which may lead to serious personal injury or death or substantial property damage.
2.  **WARNING**
Non-compliance with requirements under this heading could create circumstances which may lead to personal injury and/or which may cause damage to the Pumpset and/or ancillary equipment.
3.  **CAUTION**
Items under this heading draw attention to legal and/or statutory requirements which control the installation and use of this type of equipment. Non-compliance with these requirements may create a dangerous situation and/or result in damage to the Pumpset and ancillary equipment.
4. **NOTE:**
Items under this heading are to draw attention to assembly procedures, techniques and methods of operation etc. which are important to ensure correct installation and operation of equipment and which, if not followed, may result in damage, failure or poor performance of Pumpset and ancillary equipment.

ABBREVIATIONS:

AFL	Automatic Fill Limiting Valve
EFV	Excess Flow Valve
VRS	Vapour Removal System

SECTION 1 – GENERAL

1.1 INTRODUCTION

This publication is intended to assist those involved with the installation, operation and maintenance of Ebsray Model RB10 Regenerative Turbine Pump and the pumping system.



DANGER

Before starting any work, this publication should be completely read/reviewed by all persons involved with the work. If any part of this publication is unclear, obtain clarification before proceeding with any work.



DANGER

As LPG (Propane and Butane) is regarded as a flammable liquid, extreme caution must be taken to ensure total compliance with all necessary statutory standards, codes and regulations is fully understood and exercised in the installation, operation and maintenance of Ebsray RB10 pumps.

These instructions are intended to assist correct pump installation, operation and maintenance requirements. They are additional to, and do not supersede or override any applicable statutory, legal or regulatory requirements.

The design, materials and workmanship incorporated in the manufacture of Ebsray pumps make them capable of reliable operation over a long working life. Correct installation and operation is essential. Service life is enhanced by periodic inspection and careful maintenance.



CAUTION

Installation and servicing of this equipment should be performed by qualified competent personnel in accordance with relevant standards, codes, regulations and site restrictions, in conjunction with these instructions.

When the equipment supplied utilises components other than those manufactured by Ebsray e.g. electrical equipment, switches, fittings, valves, etc reference should be made to the original manufacturer's data before installation or servicing is commenced. Failure to observe these details may void the Warranty.



WARNING

The pumpset must be operated within the original selected design parameters of pumped product (Use only LPG of internationally accepted (ISO) quality and specification), flow, pressure, temperature, voltage and current. Should any change be contemplated, please confer with Ebsray in order to verify the suitability of such a change

1.2 TRANSPORTATION, PACKING & STORAGE

Standard domestic packing is suitable for shipment in covered transports. Pump ports must be sealed to exclude ingress of condensation, moisture or foreign material. When received on site the Pumpset must be stored in a dry covered area..

NOTE: *If Pump is not installed and commissioned immediately, special preservative techniques will be required. (Refer to Ebsray). e.g. If the Pump is installed, but not commissioned, low pressure nitrogen can be used to purge, seal and protect the Pump from the effects of condensation and atmospheric corrosion.*



WARNING

NEVER allow water or any corrosive product to enter the pump (e.g. for hydrostatic testing of pipework). Severe internal damage may result and will void the Warranty

1.3 RECEIVING INSPECTION

SHORTAGES and/or DAMAGE: On receipt of equipment, check all items against the dispatch documents and inspect for damage. Any damage or shortage incurred during transit should be noted on the packing note and on both your own and the carrier's copy of the consignment note. A claim should be made immediately on the transport company. Also advise Ebsray or their Appointed Representative.

Should a shortage be evident on receipt, notify Ebsray immediately giving full details and packing note number.

1.4 HANDLING

Do not drop Pumpset! Care should be taken in moving/handling Pump/Pumpsets in order to minimise stress on the internal components.

The Pump/Pumpset should be lifted in such a manner as to ensure compliance with the relevant lifting codes.

Severe internal Pump damage may result if correct handling and due care is not taken.

1.5 WARRANTY

1. All Ebsray manufactured pumps and equipment are warranted as standard for one (1) year against faulty workmanship and/or materials. Refer to Ebsray PUMPS 'Standard Conditions of Sale and Warranty' publication for details.
2. Ancillary equipment supplied by Ebsray but manufactured by others will be in accordance with those manufacturer's written warranty conditions

SECTION 2 – SYSTEM DESCRIPTION

2.1 EBSRAY RB10 LPG PUMPING SYSTEM

The system is designed around the RB10 Pump which is a single stage Regenerative Turbine Pump combined with a low NPSH Booster stage. The RB10 is generally baseplate mounted and direct coupled to an electric motor.

The Ebsray RB10 is designed as a 'fully serviceable' pump.

The combination of robust, specially designed, components and manufacture under an approved Quality System ensures reliable operation over the intended periods between routine maintenance overhauls.

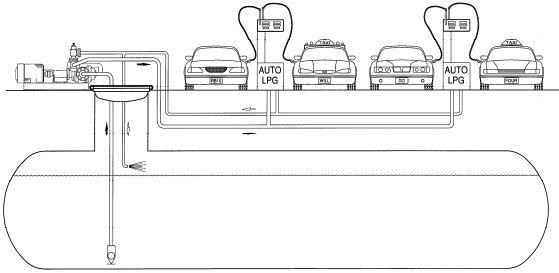

Figure 1

2.2 BYPASS VALVE – EBSRAY #RV18-VRS19

The Bypass Valve plays a pivotal role in the overall LPG system. It controls the following functions:

1. Maintains pump system differential pressure as required for optimum flow rates.
2. Ensures rapid vapour passage for faster pump priming before acting in it's liquid handling mode.

2.3 NON-RETURN VALVE

Ebsray's soft seated Non-Return Valve is important for efficient system operation and assists the pump to reach desired differential pressure more quickly. It is designed as a low-loss item during pumping and only requires a minimal pressure to lift the valve off its seat.

NOTE: *Spring actuated or high-loss non-return valves are unacceptable, and will cause the pump to fail.*

SECTION 3 – INSTALLATION

⚠ CAUTION *Installation and removal of this equipment should be performed by suitably qualified competent personnel in accordance with relevant Codes, Regulations, Standards, Directives and site restrictions - in conjunction with these instructions.*

⚠ DANGER *Never loosen or remove fittings, flanges, etc. while under pressure (vapour pressure of LPG may be very high), always isolate components or pipework and depressurise prior to work.*

3.1 LOCATION

The pump is designed for installation with an inlet pipe ideally less than 2 metres long [above ground section] from the LPG liquid withdrawal outlet of the tank - and a maximum total suction lift of 4 metres (Propane) (Refer Appendix A - P&ID for details).

NOTE: *Reducing the vertical suction lift and/or the horizontal length will reduce pump priming time and enhance performance.*

The soft seated Non-Return Valve installed in the tank on the pump inlet must have a clearance of at least 75mm from its underside to the inside wall of the tank.

Ensure no installation stresses are transferred to the Pumpset or Pump Flanges. The Pumpset may be mounted on a frame attached to the top of the tank. (Refer Appendix A - P&ID)

Ensure floor area and headroom allotted is sufficient for inspection and maintenance. Be sure to allow for crane or hoist access if required.

Ebsray recommends that the pump and the suction pipework (outside tank) are to be painted white. In addition, protection from direct sun will enhance pump priming performance.

3.2 COUPLING ALIGNMENT

If pump was supplied by Ebsray as part of a pumpset unit, pump and driver have been accurately aligned at factory. To ensure that alignment has been maintained during transit and installation, alignment **MUST BE CHECKED** prior to startup and again after the unit has been run under actual operating conditions.

NOTE: *The following procedures are typical only and reference should be made to data for specific coupling types.*

ANGULAR MISALIGNMENT as shown in Fig.2 should be corrected before eccentricity. Refer Fig.4. Use feeler gauge reading at 90° intervals, the amount of correction necessary can be easily determined to bring shaft axes in line.

Misalignment due to **ECCENTRICITY** as shown in Fig.3 can now be corrected. Refer Fig.5.

Adjustment by use of shims under the driver or pump will effectively correct error in the vertical plane.

Movement of one of the ends horizontally will correct error in the horizontal plane. If both coupling halves are of identical diameter, concentricity may be checked with a straight edge at 90° intervals.

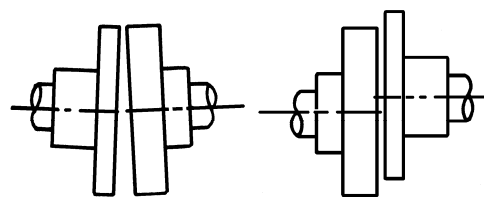

Figure 2

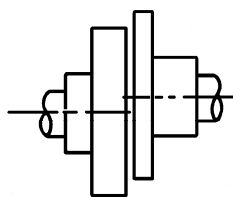

Figure 3

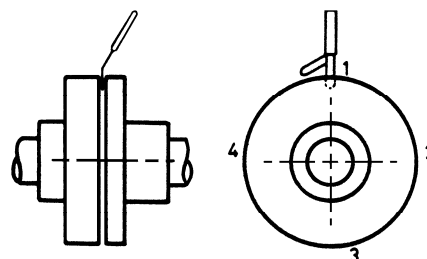

Figure 4

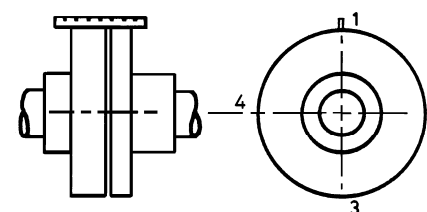

Figure 5

NOTE: *Couplings must be of the non-sparking design and be in compliance with the relevant Codes, Regulations, Standards and Directives.*

3.3 FOUNDATIONS

Baseplate units should be accurately installed. When on a concrete foundation, ensure that it has been poured on a solid footing.

3.4 PUMP PIPING CONNECTIONS

NOTE: *Debris e.g. welding slag, pipe scale, grinding swarf, shot blast material etc. left in the pipework or tank can be drawn into the pump causing serious damage and voiding the Warranty. Clean tank and pipework **TOTALLY** prior to pumpset installation*

All piping should be supported independently and line up accurately with the pump ports.

3.5 SYSTEM PIPING CONNECTIONS

⚠ CAUTION *Installation and removal of this equipment should be performed by qualified competent personnel in accordance with relevant standards, codes, regulations, and site restrictions in conjunction with these instructions.*

Refer to P&ID Appendix A for system arrangement and relative positioning of components.

⚠ WARNING *It is extremely important that no piping stresses be transferred to the pump.*

3.5.1 Foot Valve (Non-Return Valve)

Fit 50mm (2" dia.) Foot Valve (Non-Return Valve) to suction pipe in vertical position. Ensure that Foot Valve is 100% leak free by testing with water before fitting to tank. Do not test under high pressure or with nitrogen or LPG as this will falsify actual "as installed" conditions.

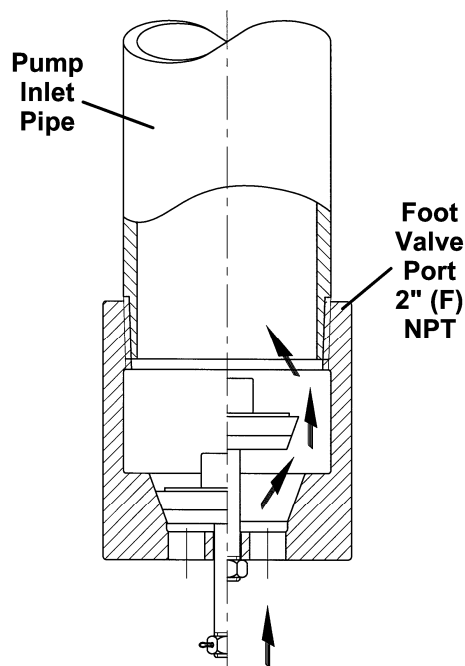

Figure 6 Non-Return Valve Detail

3.5.2 Pump Inlet Pipe

The RB10 priming performance is enhanced if:

- Vertical suction lift is minimised. (Refer Appendix A - P&ID)
- Aboveground (exposed) piping is the shortest length possible – combined with the minimum diameter (without causing cavitation) – to reduce the contained 'vapour volume' when priming (Refer Appendix A - P&ID)

3.5.3 Pump Discharge Pipe

Discharge pipe size is generally dependent upon run lengths at the specific site. Typical sizes are: 25mm (1" dia.) minimum, 32mm (1-1/4" dia.), 38mm (1-1/2" dia.), 50mm (2" dia.) (Refer Appendix A - P&ID).

3.5.4 Bypass Valve

Bypass Valve (Ebsray Model RV18-VRS19) is installed in discharge line and returns back-to-tank. This Bypass Valve is primarily for control of system differential pressure. (Variation in tank pressure has a direct affect upon discharge pressure whilst constant differential pressure is maintained).

However, a critical function performed by this unique 'VRS' Bypass Valve is its vapour handling capability during the pump start-up priming cycle. This is achieved by the VRS (Vapour Removal System). Refer to Ebsray Bypass Valve Brochure for details and functionality.

Fit Bypass Valve into bypass line. Ensure correct orientation i.e. flow is 'IN' from pump discharge line and 'OUT' returns to tank.

Flow during bypassing should return to Storage Tank vapour space

NOTE: The Bypass Valve's return-to-tank pipeline **MUST NOT** have any restrictions such as Back Check Valves or other devices which may interrupt an otherwise "zero restricted" open flow path back to the vessel.

An Excess Flow Valve is an acceptable 'normally open' device at the vessel - but under **NO** conditions should a Back Check Valve (non-return valve) be installed.

SECTION 4 – OPERATION

4.1 DESCRIPTION

The RB10 Pumpset is designed to provide trouble-free & safe operation in potentially explosive environments provided it is operated in accordance with the following recommendations.

1. Pump

The Ebsray Model RB10 pump is a compact Regenerative Turbine pump-motor unit, designed for pumping LPG of Internationally accepted (ISO) quality and specification.

The Pump meets the requirements of Australian, European ATEX and other International Standards and Codes for use in potentially explosive atmospheres.

2. Motor

Standard RB10 pumpsets are available from Ebsray using Direct Coupled 2,880 RPM (4kW or 5.5kW 50hz) or 3,500 RPM (5.5kW or 7.5kW 60hz) Electric Motors. Ebsray can supply other options to suit customer requirements. The RB10 pump can also be driven by other means such as belt drive, diesel engines etc. Ensure motor conformity with all necessary Codes, Regulations, Standards, Directives and site requirements.

3. Coupling

Non-Sparking design (e.g. "polygear" type) – sized to suit duty. Supplied by Ebsray or customer supplied.

4.2 LUBRICATION

The Ball Bearings for RB10 pumps are grease lubricated and 'sealed-for-life' design.

No 'in service' lubrication is required on EBSRAY's RB10 Pumps.

For motor, refer to specific motor manufacturer's recommendations.

4.3 PRE-STARTUP CHECKLIST

Refer to pre-start inspection checklist (Appendix B)



WARNING

Do not run Pumpset dry. Do not start Pump against closed Discharge Valve. Severe internal damage to the Pumpset will result, voiding Warranty.

4.4 STARTUP PROCEDURE

Fill in the 'Pump Run Log' provided in Appendix C

1. Ensure all conditions described in Pre-Startup Checklist have been met.
2. Check reading on discharge pressure gauge. Record product vapour pressure in the commissioning section of the Pump Run Log.
3. Back-off Bypass Valve Adjusting Screw (screw to maximum 'out' position).
4. Verify all site conditions and statutory requirements have been met.
5. Briefly activate power (i.e. 'jog' motor) to verify correct pump rotation. (Cast arrow on cover)
- 6 Start Pumpset.



WARNING

If any aspect of the pumpset or pumping system does not function properly, immediately turn the pump 'off' and rectify the problem before re-starting.

7. After startup, pump should immediately begin to build **differential pressure**. If pump does not prime immediately, switch off to determine reason and rectify before re-starting.
 8. After startup, initially ensure that liquid is flowing through Bypass Valve. This should be detectable by listening or feeling the Bypass Valve. Screw 'in' the Bypass Valve Adjusting Screw until the required system differential pressure is achieved. Record discharge pressure in the commissioning section of the Pump Run Log.
 9. Check that motor current is below FLA rating. Record motor current readings in the commissioning section of the Pump Run Log.
- NOTE: During this procedure, or at any time, motor current must not exceed FLA rating of motor.**
10. Stop pump, restart and check for consistent results.
 11. Record discharge pressure and current readings in the commissioning section of the Pump Run Log.
 12. The Pumpset is now ready for normal operation.
 13. After final Bypass Valve adjustment, tighten adjusting screw locknut and seal for security.
 14. The startup procedure is now complete.
 15. Inspect Pumpset/pumping system frequently during the first few hours of operation then periodically thereafter (see Section 4.5 for frequency). Record observations from these inspections in the Pump Run Log.

4.5 PERIODIC INSPECTION

Periodic Inspection of the Pump, Pump System and Ancillary Equipment is required to maintain safety, conformity, operational functionality and reliability. Ebsray recommends a maximum interval of three months or 500 hours operation between routine periodic maintenance inspections (More frequent inspections may be necessary dependent upon usage, site conditions, operation etc).

If any abnormal condition is discovered, cease operation of pump immediately and take action to rectify the problem. Record observations from these inspections in Pump Run Log.

For safe operation, the following items should be included in the routine periodic inspection:

- a. Inspect the Pump for LPG leaks, vibration, abnormal noises, signs of overheating, discolouration, etc.
- b. Inspect Coupling Assembly for signs of wear, overheating, discolouration, etc.
- c. Check Pump differential pressure
- d. Check Motor Current.
- e. Inspect motor for vibration, abnormal noises, signs of overheating, discolouration, etc.

SECTION 5 – MAINTENANCE

CAUTION Prior to any system disassembly or service, verify that all requirements of statutory Codes, Regulations, Standards & Directives are met and that specific site requirements etc are satisfied.

Some minor maintenance tasks and inspections can be performed with the pump 'in line' so long as complete isolation, depressurising and purging procedures have been completed. However for major maintenance it is recommended that the pump be removed from the installation

5.1 PREPARATION FOR DISASSEMBLY

1. Obtain the appropriate Work Permit if required.
2. Isolate power supply to motor.
3. Isolate pump from LPG system, depressurise and purge out any LPG liquid or vapour in a safe approved manner.
4. Disconnect porting connections.
5. Remove pump from installation.

5.2 DISASSEMBLY

1. Remove pump coupling half.
2. Disconnect Transfer Manifold between first stage discharge to second stage suction.
3. Remove First Stage Impeller Housing and accompanying O-Ring complete with Diffuser and First Stage Impeller Housing Bearing.
4. Unscrew three screws from First Stage Impeller, push First Stage Impeller forward to break from tapered collet and remove Impeller from Shaft.
5. Remove Suction Manifold and accompanying O-Ring, complete with Neck Ring.
6. Remove Cover, complete with Bearing and accompanying O-Ring. **NOTE:** Two extraction holes, tapped M10 x 1.5 are provided to facilitate removal. (Cover bolts suit.)
7. Withdraw Second Stage Impeller and remove key. **NOTE:** Two extraction holes, tapped M6 x 1.0 are provided to facilitate removal.
8. Release two grub screws on Seal Sleeve sufficiently to clear Shaft, this enables withdrawal of Seal Sleeve and Rotary Seal Face assembly. **NOTE:** Two extraction holes, tapped M6 x 1.0 are provided to facilitate removal.
9. Remove Body and accompanying Seal Seat.
10. Press out Bearings and Shaft assembly from Bracket, which also removes Throttle Bush and O-Ring.
11. Remove Circlip and press Bearings off Shaft.

5.3 INSPECTION

1. Check First Stage Impeller, Diffuser and Neck ring for damage. Replace as required.
2. Inspect both carbon Sleeve Bearings for damage or wear. Running clearances should not exceed:
 - a) For Cover Bearing 0.15mm
 - b) For First Stage Impeller Housing Bearing 0.25mm
3. Check Shaft for run-out, particularly if any Bearing journals are worn. Replace as required.
4. Check Second Stage Impeller and Seal Zone of Body for damage or wear. Replace Impeller if blades have been broken or wear is excessive. Refer Figure.7.

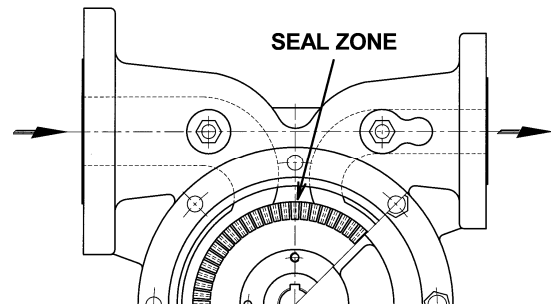

Figure 7

Second Stage Impeller Dimensions:	
Minimum Width:	8.86mm
Minimum Diameter	129.86mm

5. Inspect both Ball Bearings for wear. It is recommended on major overhauls that Ball Bearings be replaced.

Bearing Replacement recommended at 10,000 operational hours.

6. Check Mechanical Seal Faces for wear or damage. Replace as required.
7. It is recommended that O-Rings and flange gaskets be replaced at every overhaul.

5.4 SPARE PARTS

1. When ordering spare parts, to ensure a minimum of delay and correct replacement to original specification, **ALWAYS** quote the pump Serial Number located on the nameplate of the pump.
2. Advise the name, Cat # and quantity required. Refer Section 6 – Parts Designation.
3. Advise complete delivery instructions, transportation, etc.



DANGER

Substitute or so-called 'equivalent' item/spare parts are not recommended for use. Compliance, safe operation and pump performance may be severely compromised if incorrect or substitute spare parts – including Fasteners, O-Rings, Ball Bearings, etc – are used.

5.5 REASSEMBLY - PRELIMINARY

1. Ensure all parts are clean before assembly. Remove any burrs.
2. If replacement was required fit carbon Bearings to both First Stage Impeller Housing and Cover ensuring correct running clearance (refer "inspection").
3. Ensure Second Stage Impeller maintains an accurate free sliding fit on Shaft and key.



CAUTION At all times when handling and installing mechanical seals, care must be taken to ensure lapped faces and seats are not damaged. Particular attention must be given to carbon seats to prevent marking or chipping.

4. Lightly lubricate all O-Rings with a good quality, compatible, detergent-free light oil before assembly. A dab of compatible grease on each seal spring will assist in keeping the springs positioned in the holes during assembly.
5. Assemble Rotary Seal Face to Seal Sleeve i.e. fit two O-Rings to grooves, position six Springs in holes and ensure Drive Pin location. Rotating Face must be free to follow axially by spring pressure.

5.6 REASSEMBLY

(Refer Section 6 – Parts Designation)

Pump Fastener Torque settings:		
M10	ISO Grade 8.8	55Nm
M16	ISO Grade 8.8	100Nm
M20	ISO Grade 8.8	200Nm
M20....	ISO Grade 8	(nut)

1. Fit Ball Bearings (24,23) to Shaft (21) – small Bearing (24) to drive end of Shaft. Press home and fit Circlip (25) to groove adjacent to Inspection End Bearing.
2. Fit Bearings and Shaft assembly into Bracket (20) and press home.
3. Fit O-Ring (26) into Bracket (20).
4. Fit Throttle Bush (28) into Bracket (20) with drain hole in six o'clock position and facing out (ie towards Inspection End).
5. Fit O-Ring (48) to Seal Seat (40) and fit Seal Seat into Body (1).
6. Fit Body (1) to Bracket (20) ensuring Seal Seat (40) is not damaged.
7. Lightly lubricate Rotary Seal Face (41) and Seal Seat (40) with a good quality, compatible, detergent-free light oil.
8. Push Seal sub-assembly (42,41) onto Shaft (21) until positive location is felt. Apply a medium strength thread locking adhesive (eg Loctite 243 or equivalent) to grub screws and lock grub screws (43) tightly onto Shaft (21) checking that axial position has been maintained.

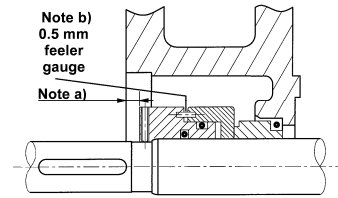

Figure 8

Notes re Figure 8:

- a) Check that there is clearance between Seal Sleeve (42) and Body (1) face.
 - b) Ensure that a gap of approximately 0.5mm exists between Seal Sleeve (42) and Rotary Seal Face (41).
9. Fit Key (8) to Shaft (21) and slide Second Stage Impeller (3) onto Shaft.
 10. Fit O-Ring (4) on Cover (2) and assemble Cover (2) complete with Cover Bearing (65) onto Body (1). Ensure seal zone on Cover faces seal zone on Body by matching dowel holes in cover and body.
 11. Fit O-Ring (71) on Suction Manifold (61) and bolt Suction Manifold (61), Cover and Body together. Ensure Neck Ring (64) has been fitted to Suction Manifold (61).

NOTE:

Shaft should turn freely after tightening bolts. If tightening of Cover prevents Shaft from being turned, check for burrs on Impeller or Mechanical Seal Sleeve position.

12. Slide First Stage Impeller (62) onto Shaft, apply a medium strength thread locking adhesive (eg Loctite 243 or equivalent) to the three screws and lock Impeller so that the distance from the stepped face on Suction Manifold to the outside face of Impeller is 10mm. (Refer Figure 9)

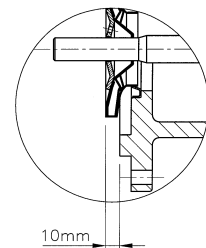

Figure 9

13. Fit O-Ring (72) to Suction Manifold (61) and bolt First Stage Impeller Housing (60) complete with Bearing (66) and Diffuser (63) to Suction Manifold (61). **NOTE:** Ensure Diffuser is positioned as shown in Figure 10.

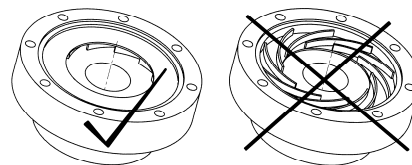
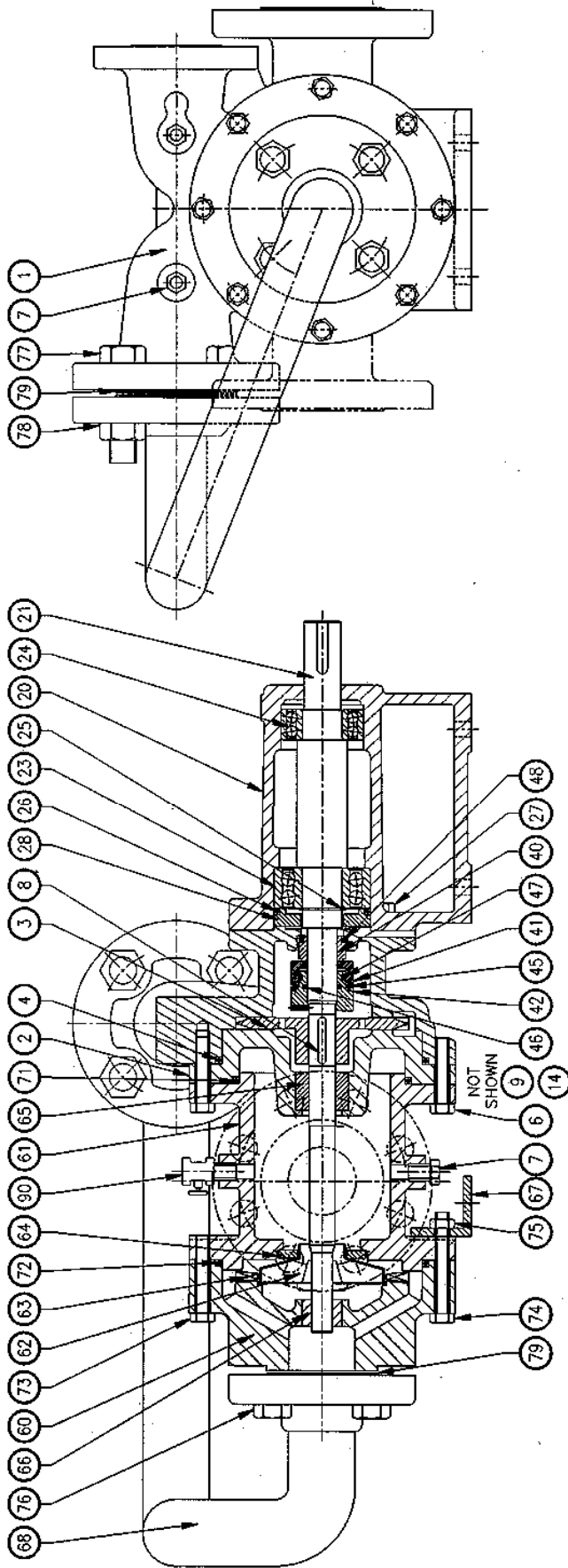

Figure 10

14. Check that the Shaft turns freely after tightening bolts.
15. Using new gaskets, fit Transfer Manifold (68) connecting First Stage discharge to Second Stage Suction.
16. Fit pump coupling half to Shaft.

SECTION 6 – PARTS DESIGNATION

MODEL: RB10 Regenerative Turbine Pump



Cat#	Description	Qty	Cat#	Description	Qty	Cat#	Description	Qty
1	Body	1	28	Throttle Bush	1	62	First Stage Impeller	1
2	Cover	1	40	Seal Seat	1	63	Diffuser	1
3	Second Stage Impeller	1	41	Rotary Seal Face	1	64	Neck Ring	1
4	O Ring – Cover	1	42	Seal Sleeve	1	65	Cover Bearing	1
7	Plug	3	43	Grub Screw – Seal Sleeve	2	66	Impeller Housing Bearing – First Stage	1
8	Key	1	44	Drive Pin – Seal Sleeve	1	67	Mounting Foot	1
20	Bracket	1	45	Seal Spring	6	68	Transfer Manifold	1
21	Shaft	1	46	O Ring – Shaft	1	71	O-Ring – Suction Manifold	1
23	Bearing – Inspection End	1	47	O Ring – Seal Sleeve	1	72	O-Ring – First Stage Impeller Housing	1
24	Bearing – Drive End	1	48	O Ring – Seal Seat	1	79	Gasket	2
25	Circlip	1	60	Impeller Housing- First Stage	1	90	Vent Valve	1
26	O Ring – Bracket	1	61	Suction Manifold	1			

SECTION 7 – TROUBLESHOOTING

Symptom	Possible Problem	Possible Cause	Remedy
No Vehicle Fill	Pump operating but fails to deliver LPG	Vehicle Tank already full	No problem exists
		Insufficient LPG in Storage Tank	Fill Storage Tank
		Excessive pressure in Vehicle Tank compared to Storage Tank	Allow Vehicle Tank to cool until pressure decreases, or increase vapour pressure in Storage Tank, or increase bypass differential pressure
		Blockage in Pump inlet/discharge line	Clear blockage or remove restriction.
		Dispenser malfunctioning or not authorised correctly	Re-authorise or check Dispenser as required.
		Insufficient system discharge pressure (See “Discharge Pressure too low” Symptom below)	Increase discharge pressure (See “Discharge Pressure too low” Symptom below)
		Malfunctioning AFL Valve or blocked Filter in AFL Valve in vehicle	Repair, clean filter or replace AFL Valve in vehicle as required
		Blocked Filter in Meter/Dispenser	Check and clean or replace as required
		Blocked Filter in Nozzle	Check and clean or replace as required
		Pump not primed with LPG	Refer to “Pump running but will not generate adequate differential pressure” symptom
		Tanker unloading into storage tank during dispenser operation	Wait until unloading operation is completed and mix/temp/state has stabilised in Storage Tank
Slow Vehicle Fill	Low Pump flow	Insufficient LPG in Storage Tank - Pump Inlet (Suction) Port not fully covered with liquid	Fill Storage Tank
		Excessive pressure in Vehicle Tank	As filling proceeds, temperature (and pressure) will fall - increasing fill rate
	Low Discharge/Differential Pressure	See “Discharge Pressure too low” Symptom below	See “Discharge Pressure too low” Symptom below
	Restriction between Pump and Vehicle tank	Malfunctioning AFL Valve or blocked filter in AFL Valve in vehicle	Repair, clean filter or replace AFL Valve in vehicle as required
		Restriction in Filter of Meter/Dispenser	Check and clean or replace as required
		Restriction in Filter of Nozzle	Check and clean or replace as required
		Restriction within vehicle's fill piping or vehicle Back-Check Valve faulty	Clear restriction. Check, clean or replace as required
Excessive vehicle system resistance	High pressure drop equipment in vehicle (e.g. AFL Valve, vehicle hose, Back-check valve, etc)	Select 'lower loss' equipment in vehicle.	
Pump Will Not Run	Dispenser/ Control/ Communications System faulty or Power Supply to Motor faulty	Control System not providing signal	Check and/or repair Dispenser / Control / Communications System as required
		- no power supply to Motor - low/high voltage - loss of phase/s - imbalance of phases - etc	Check power supply Check power to: a) Main Switch Board b) Motor (with Motor running and with Motor stopped):
		Motor Overload tripped out	Determine cause of trip-out before resetting
		Contact(s) or Coil in Motor Contactor faulty	Check Contactor, repair or replace as required
	Jammed Pump	See ‘Motor using excessive power’	If is damaged internally, repair or replace as required

Symptom	Possible Problem	Possible Cause	Remedy
Pump running but will not generate differential pressure	Pump not primed	Insufficient LPG in Storage Tank	Fill Storage Tank
		Inlet Valve not open	Open Inlet Valve
		Excessive heating (sun) on inlet piping and/or Pump	Cover Pump/Piping with sunshade
			Paint Pump/Piping white
		Pump unable to clear vapour due to blockage/restriction in discharge (bypass) return line	Ensure unrestricted and fully open passage back to Storage Tank, (VRS Bypass Valve, EFV only in Storage Tank – NOT back-check-valve) replace item and/or clear blockage
		Excessive volume of vapour to be cleared	Inlet (suction) pipe too long/too large- Shorten/reduce diameter
		Tanker unloading into Storage Tank during dispenser operation	Wait until unloading operation is completed and mix/temp/state has stabilised in Storage Tank
		Normal wear after extended service	Service / Replace Pump
	Excessive Suction lift for the LPG 'mix' in Storage Tank	Decrease suction lift, or increase vapour pressure in Storage Tank	
	Pump has 'Dead Headed'	Incorrect Bypass Valve setting (too high)	Adjust (decrease) Bypass Valve setting to achieve lower pressure, not exceeding FLA of motor
		Restriction in discharge system or bypass line e.g. Discharge Isolation Valve, Bypass Valve, Bypass EFV or Isolation Valve closed	Check all devices in the discharge line or the bypass line, remove restriction, repair or replace as required
		Normal wear after extended service	Service/Replace Pump
	Incorrect Pump rotation	Incorrect wiring to Motor	Reverse rotation by rewiring connections to motor
Motor using excessive power or Motor over-heating	Differential Pressure too high	Incorrect Bypass Valve Setting. (too high)	Adjust (decrease) Bypass Valve setting to achieve required lower pressure, not exceeding FLA of motor
		Pump has restriction in discharge system or bypass line e.g. Discharge Isolation Valve, Bypass Valve, Bypass EFV or Isolation Valve closed	Check all devices in the discharge line or the bypass line, remove blockage, repair or replace as required
		Discharge Valve not fully open	Check Actuator and/or Open Discharge Valve
	Power Supply to Motor incorrect	Power supply faulty e.g. - low/high voltage - loss of phase/s - imbalance of phases - etc	Check power supply (with Motor running and with Motor stopped): a) To Main Switch Board b) To Motor
	Pump jammed or damaged internally	Dirt/debris/contaminate from Storage Tank and/or suction pipe.	Remove dirt/debris/contaminate from Pump, Storage Tank and/or inlet pipe before restarting Pump
		Impeller(s) damaged	Replace Impeller(s) and inspect for other damage to pump
		Normal wear after extended service	Service/Replace Pump
	Motor rapid cycling	Excessive start per hour (Refer motor manufacturer for maximum)	Limit start per hour or frequency of starts. (Refer Ebsray)

Symptom	Possible Problem	Possible Cause	Remedy
Discharge Pressure too low	Differential Pressure too low	Insufficient LPG in Storage Tank	Fill Storage Tank
		Incorrect Bypass Valve setting.	Adjust (Increase) Bypass Valve setting to achieve required differential pressure – not exceeding FLA of motor
		Bypass Valve jammed open or faulty	Check Bypass Valve, remove any obstruction, roughness, corrosion etc.
		Pump has-restriction in discharge system or bypass line e.g. Discharge Isolation Valve, Bypass Valve, Bypass EFV or Isolation Valve closed	Check all devices in the discharge system and bypass line, remove blockage, repair or replace as required
		Excessive Inlet (suction) restriction - Inlet Isolation Valve not opened fully - Faulty Inlet Excess Flow Valve	Check / open Inlet Valve Check, repair or replace Inlet Excess Flow Valve as required
		Tanker unloading into Storage Tank during dispenser operation	Wait until unloading operation is completed and mix/temp/state has stabilised in Storage Tank
		Normal wear after extended service	Service/Replace Pump
		Discharge Valve not fully open	Check Actuator and/or Open Discharge Valve
	Low Vapour Pressure in Storage Tank	High %Butane in Storage Tank	Increase Vapour Pressure (e.g. add Propane) or increase LPG temperature
		Low temperature in Storage Tank	Increase LPG temperature
Excessive Noise and/or Vibration	Obstruction in Pump	Dirt/debris/contaminate lodged in Pump	Remove dirt/debris/contaminate from Pump, Storage Tank and/or inlet pipe before restarting Pump
	Faulty EFV on inlet, Bypass or Discharge	EFV Spring faulty or EFV ports partially blocked or jammed	Check EFV(s), repair or replace as required
	Faulty Back-check Valve in Discharge Line	Inspect Back-Check Valve: Spring, Seat, Poppet, Flapper etc.	Repair or replace Back-Check Valve as required
	Faulty Bypass Valve	Improperly set Bypass Valve or Bypass Valve faulty, jammed, etc	Check Bypass Valve, adjust, repair or replace as required
	Pump or Motor Ball Bearings worn	Normal wear after extended service	Service Pump or Motor (use certified/qualified persons only)
	Faulty AFL Valve in vehicle	Malfunctioning AFL Valve in vehicle	Repair/Replace AFL Valve in vehicle as required
"Pulsing" Flow and/or Pump losing prime	Pump cavitating or making vapour	Insufficient LPG in Storage Tank - Pump Inlet (suction) Port not fully covered with liquid	Fill Storage Tank
		Excessive Inlet (suction) restriction - Inlet Valve not opened fully - Faulty Inlet Excess Flow Valve	Check / Open Inlet Valve, repair or replace Excess Flow Valve as required
		Excessive Suction lift for the LPG 'mix' in Storage Tank	Decrease suction lift or increase %Propane in Storage Tank
	Pump has 'Dead Headed'	Incorrect Bypass Valve setting (too high)	Adjust (decrease) Bypass Valve setting to achieve lower pressure, not exceeding FLA of motor
		Restriction in discharge system or bypass line e.g. Discharge Isolation Valve, Bypass Valve, Bypass EFV or Isolation Valve closed	Check all devices in the discharge line or the bypass line, remove restriction, repair or replace as required
		Normal wear after extended service	Service/Replace Pump

APPENDIX A – TYPICAL INSTALLATION P&ID

IMPORTANT NOTES

- 1 This P&ID is **TYPICAL ONLY** and Only Relates to the Specifications of the Minimum Equipment Required to Ensure the Optimum Performance, Maximum Life and Trouble-Free Operation of the Ebsray RB10 Pumpset and the Pumping System in General.
- 2 This P&ID Does **NOT** Depict:
 - 2.1 Ancillary Required Equipment Related to the Fabrication, Installation and Operation of the Pumpset e.g. Misc. Flanges, Fittings, Etc..
 - 2.2 Required Equipment unrelated to the Pumpset e.g. Tank Fill Lines, Vapour Return Lines, Emergency Shutdown Systems, Etc.
 - 2.3 The Materials and Method of Fabrication and/or Installation of the Tank and Required Sub-Systems.
- 3 It is the Responsibility of the Designer, Fabricator and the Installer of Each Actual Tank and Required Sub-Systems to Ensure that:
 - 3.1 The Ebsray Specifications within this P&ID and any other Relevant Ebsray Documents are **STRICTLY** Adhered to.
 - 3.2 Any Variation (Including Use of Equipment Deemed "Equivalent") or Addition to the Ebsray Specifications, as Related to the Pumpset and the Pumping System in General, meet Ebsray's Minimum Requirements.
 - 3.3 All Design, Fabrication and Installation of the Tank and Required Sub-Systems is **STRICTLY** in Accordance with all Relevant Federal, State and Local Codes, Regulations and Standards.
- 4 Ebsray Reserves the Right to:
 - 4.1 Withdraw or Alter Any or All of the Ebsray Specifications within this P&ID and any other Relevant Ebsray Documents without Notification.
 - 4.2 Determine the Validity of Any Warranty Claims for Ebsray Equipment Based on the Proper Application of Ebsray Supplied Equipment by the way of Adherence to the Ebsray Specifications within this P&ID and any other Relevant Ebsray Documents.

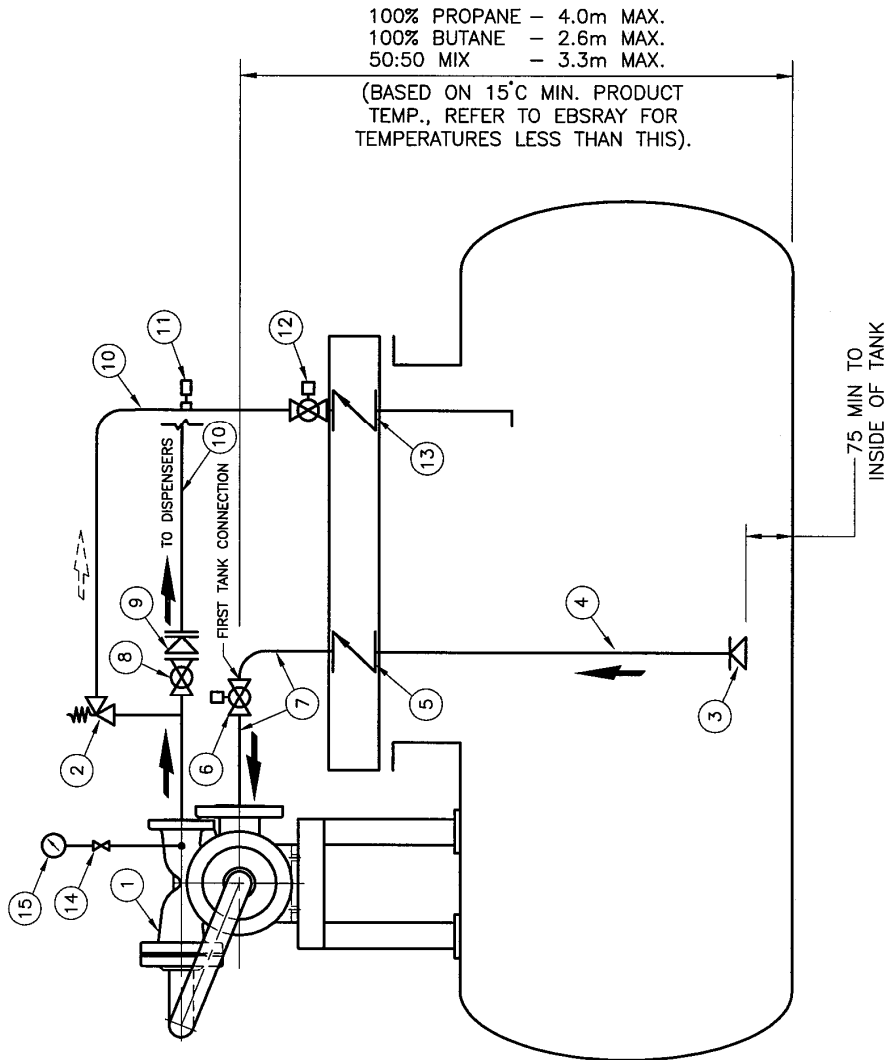

ITEM	DESCRIPTION	SUPPLY	QTY
1	EBSRAY 'RB10' PUMPSET FLANGED 50NB INLET, 25 NB DISCHARGE ANSI 300	EBSRAY	1
2	EBSRAY RV18-VRS19 BYPASS VALVE FLANGED 25 NB ANSI 300	EBSRAY	1
3	EBSRAY SOFT SEATED NON-RETURN VALVE LB50002 50 NB (F)NPT	EBSRAY	1
4	50 NB PIPE (PUMP INLET - IN TANK)	COM'L	1
5	50 NB EXCESS FLOW VALVE REGO A3292C (OR EQUAL)	COM'L	1
6	40 NB FULL BORE PNEUMATIC ACTUATED BALL VALVE	COM'L	1
7	40 NB PIPE (PUMP INLET-ABOVE GROUND)	COM'L	1
8	25 NB FULL BORE (MIN) BALL VALVE	COM'L	1
9	32 NB (MIN) SOFT SEATED 'IN-FLANGE' BACK CHECK VALVE	COM'L	1
10	32 NB PIPE (PUMP DISCHARGE & BYPASS RETURN)	COM'L	1
11	8 NB HYDROSTATIC RELIEF VALVE	COM'L	1
12	25 NB FULL BORE (MIN) PNEUMATIC ACTUATED BALL VALVE	COM'L	1
13	25 NB (MIN) EXCESS FLOW VALVE (NOT NON-RETURN VALVE)	COM'L	1
14	8 NB ISOLATION VALVE	COM'L	1
15	63mm, 0-2500 kPa PRESSURE GAUGE	COM'L	1

TYPICAL INSTALLATION P&ID-AUS
EBSRAY RB10 PUMP
DRG. No. A312001K REV. A
21-08-02

EBSRAY
AUSTRALIA
EBS-RAY PUMPS PTY.LTD
A.C.N. 001 061 003

APPENDIX B – SYSTEM PRE-STARTUP COMMISSIONING CHECKLIST

Date: _____ Pumpset Serial No. _____

Location: _____ Bypass Valve Model No / Serial No: _____

Installation Company: _____ Installer's Name: _____

Indicate Inspection Satisfactorily Completed with a in the appropriate box

- 1. Check for leak free installation at Pump and pipe connections.
- 2. Check for correct pipe/port orientation (check IN / OUT marking on Pump).
- 3. Ensure voltage is correct and that all relevant electrical components are adequate for the application.....
- 2. Ensure motor overload relay setting does not exceed FLA of motor.....



WARNING

***Do not run Pump in reverse.
Severe internal damage to the Pump may result.***

- 5. Direction of rotation –
This **MUST** be tested prior to Pump operation (check marking on Pump)



WARNING

***Do not run Pump dry.
Severe internal damage to the Pump will result, voiding Warranty.***

- 6. Valves should be in the following positions:
(see Appendix A – P&ID for locations)
 - Pump Inlet Valve.....OPEN.....
 - Valves to both Pressure GaugesOPEN.....
 - Discharge Line Valve/sOPEN.....
 - Vapour/Bypass Return Line Valve/s.....OPEN.....



WARNING

***Do not start Pump against closed Discharge Valve or
with Inlet Valve closed or throttled***

- 7. Ensure Storage Tank has adequate liquid and Pump is liquid filled before starting motor.....
- 8. Back off Bypass Valve Adjusting Screw fully i.e. Minimum differential pressure.....

Notes:

APPENDIX D – DECLARATION OF CONFORMITY



Publication No 2012-10

EC-DECLARATION OF CONFORMITY

In accordance with Annex X of ATEX Directive 94/9/EC and Annex II 1A of Machinery Directive 2006/42/EC

EC-DECLARATION OF INCORPORATION

In accordance ANNEX II 1B of Machinery Directive 2006/42/EC

<i>Item</i>	
Manufacturer	Ebsray Pumps Pty Ltd
Address	628 Pittwater Road Brookvale NSW 2100 Australia
Manufacturer's Declaration	We, Ebsray Pumps Pty Ltd, declare that the following equipment :
Description of Equipment	Ebsray R Series Regenerative Turbine Pump ; Model / Type : RC20 (all Types) RC25 (all Types) R10 (all Types) RB10 (all Types) for pumping LPG and other light liquids ; and bearing the following marking : II 2 G c T4 CE
Declaration of Compliance	Is designed and manufactured in compliance with the following applicable Directives :
Applicable Directives	
First applicable Directive	ATEX Directive 94/9/EC - by application of the following Standards :
Applied Harmonised Standards	EN 1127-1 (2007) EN 13463-1 (2001) EN 13463-5 (2003)
Second applicable Directive	Pressure Equipment Directive (PED) 97/23/EC - but excluded under Article 3.10
Third applicable Directive	Machinery Directive (MD) 2006/42/EC – by application of the following Standards:
Applied Harmonised Standards	EN 809 (1998) EN ISO 12100-1 (2003) EN ISO 12100-2 (2003) EN ISO 14121-1 (2007)
Manufacturer's own warning	Subject to the use for which the products were designed and/or installed in accordance with the relevant Standards and Codes – all in conjunction with the Manufacturer's own Installation and Operating Instructions and recommendations. This Declaration of Conformity will become invalid upon unauthorised modification and/or use/operation other than intended.
Final Declaration of Conformity	We, the undersigned, hereby declare that the products specified conform to the relevant Essential Health and Safety Requirements of the listed Directives and conform to the relevant clauses of the listed Standards
Final Declaration of Incorporation	We, the undersigned, hereby declare that the partially completed machinery listed is intended to be incorporated into machinery/assembled with other machinery. The relevant Essential Health and Safety Requirements of the listed Directives have been applied and fulfilled. The technical file defined in Annex II 1B has been prepared. The partially completed machinery is not to be put into service until the machinery into which it is to be incorporated has been declared in conformity with the provisions of the Machinery Directive 2006/42/EC
Signatory of person legally responsible and authorised to prepare the technical file.	Ebsray Pumps Pty Ltd W.A.Ebsary - Managing Director Unit 43, Enterprise City Green Lane, Spennymoor County Durham, DL16 6JF United Kingdom
Place / Date	Brookvale, Australia / 16 January 2010



Publication No 2041-05

EC DECLARATION OF CONFORMITY

<i>Item</i>	<i>Content based upon Annex X of ATEX Directive 94/9/EC</i>
Manufacturer	Ebsray Pumps Pty Ltd
Address	628 Pittwater Road Brookvale NSW 2100 Australia
Manufacturer's Declaration	We, Ebsray Pumps Pty Ltd declare that the following equipment :
Description of Equipment	Ebsray Polygear Series Mechanical Shaft Coupling ; Model / Size / Type : 575 (all Sizes) (all Types) for pumps in LPG and other liquid service ; and bearing the following marking : II 2 G c T4 CE
Declaration of compliance	Is designed and manufactured in compliance with the following applicable Directives :
Applicable Directives evaluated by Manufacturer - not checked by Notified Body	
First applicable Directive 1.	ATEX Directive 94/9/EC - by application of the following Standards :
Individual declaration of compliance	EN 1127-1 (1998) EN 13463-1 (2001) EN 13463-5 (2003)
Second applicable Directive	Machinery Directive (MD) 98/37/EC – by application of the following Standards :
	EN ISO 12100-1 (2003) EN ISO 12100-2 (2003)
Manufacturer's own warning	Subject to the use for which the product(s) were designed and/or installed in accordance with the relevant Standards and Codes – all in conjunction with the Manufacturer's own Installation and Operating Instructions and recommendations
Final declaration	We, the undersigned, hereby declare that the product(s) specified conform to the listed Directive(s) and Standard(s)
Signatory of person legally responsible	Ebsray Pumps Pty Ltd W.A.Ebsary - Managing Director
Place / Date	Brookvale, Australia / 10 September 2004

NOTES

