

# BLACKMER PARTS LIST

## PUMP MODEL: NPH4F

Keep with Instructions 103-A00 for Installation, Operation and Maintenance

Section 103  
Effective Oct 2012  
Replaces New

See page 2 for pump with Electric Heat Option.

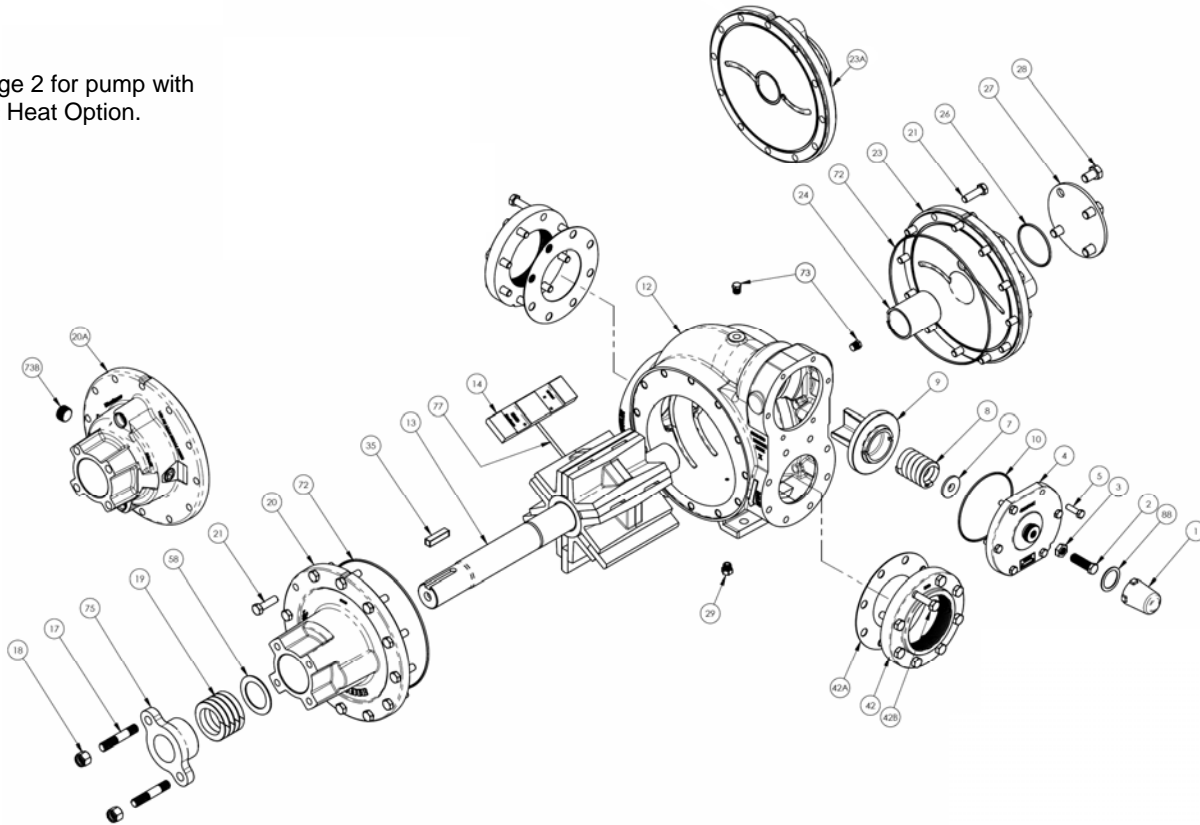

Ref. No.	Description	Parts per Pump	Part No.	Ref. No.	Description	Parts per Pump	Part No.
1	Cap - Relief Valve (R/V)	1	413957	20	Head & Bushing Asy. - Inboard	1	031976
2	Adjusting Screw - R/V (Std.)	1	436307	20A	Head & Bushing Asy. - Inboard (Jacket)	1	031972
	Adjusting Screw - R/V <sup>1,4</sup> (high pressure)		436311	21	Capscrews - Head	24	920532
3	Locknut - Adjusting Screw	1	436355	23	Head & Bushing Asy. - Outboard	1	031977
4	Cover - R/V (Std.)	1	411968	23A	Head & Bushing Asy. - Outboard (Jacket)	1	031973
	Cover - R/V <sup>1,4</sup> (high pressure)		411969	24	Bushing (Sleeve Bearing)	2	<sup>5</sup> 161900
5	Capscrew - R/V Cover (Std.)	6	920351	26	O-Ring - Bearing Cover (FKM) (Std.)	1	<sup>5</sup> 702222
	Capscrew - R/V Cover <sup>1,4</sup> (high pressure)		920421		O-Ring - Bearing Cover (PTFE)		702225
7	Spring Guide - R/V	1	426355		O-Ring - Bearing Cover (Buna-N) <sup>4</sup>		702219
8	Spring - R/V (51-75 psi)	1	476310	27	Bearing Cover	1	041900
	Spring - R/V (76-150 psi)		476305	28	Capscrews - Bearing Cover	4	920611
	SS Spring - R/V (51-75 psi)		476314	29	Pipe Plug Asy. (SAE # 6) (FKM) (Std.)	1	908212
	SS Spring - R/V (76-150 psi)		476321		Pipe Plug Asy. (SAE # 6) (PTFE)		908213
SS Spring - R/V (151-200 psi) <sup>1,4</sup>	476969	35	Key - Shaft	1	<sup>5</sup> 909191		
9	Valve - R/V (Std.)	1	456315	42	See Page 4 for Flange Options		
	Valve - R/V (Nickel Plated) <sup>4</sup>		456300	72	O-Ring - Head (FKM) (Std.)	2	<sup>5</sup> 702128
10	O-Ring - R/V Cover (FKM) (Std.)	1	<sup>5</sup> 702229	O-Ring - Head (PTFE)	702129		
	O-Ring - R/V Cover (PTFE)		702230	O-Ring - Head (Buna-N) <sup>4</sup>	702127		
	O-Ring - R/V Cover (Buna-N)		702228	73	Gage Plug	2	908198
12	Cylinder (Std.)	1	021915	73B	Jacket Plug	0-4	908223
	Cylinder w/ SAE Drain (Ductile Iron) <sup>4</sup>		021916	77	Push Rods	3	<sup>5</sup> 121905
13	Rotor & Shaft, Open Rotor (Shown)	1	261968	88	Gasket - R/V Cap	1	<sup>5</sup> 533909
	Rotor & Shaft, Closed Rotor (Optional)		261980	—	Kit - Maintenance	—	898932
14	Vane - Duravane (Std.) <sup>2</sup>	6	<sup>5</sup> 091924	EC = Extra Clearance    SS = Stainless Steel <sup>2</sup> 150 psi maximum for Duravanes <sup>5</sup> Included in Maintenance Kit			
	Vane - EC Laminate <sup>4</sup>		091931				
	Vane - EC Cast Iron		091952				
	Vane - EC Bronze		091953				

<sup>1</sup> High Pressure Relief Valve parts must be used as a group (includes p/n's 436311, 411969, 920421, and 476969) (ref 2, 4, 5 & 8).

<sup>4</sup> AFFF service pumps include: Nickel Pltd. High Press. RV, 200 psi RV spring, Buna O-rings, Cyl. w/ Drain, Lip Seal & EC Laminate Vanes.

# Pumps with Heads for Electric Heating

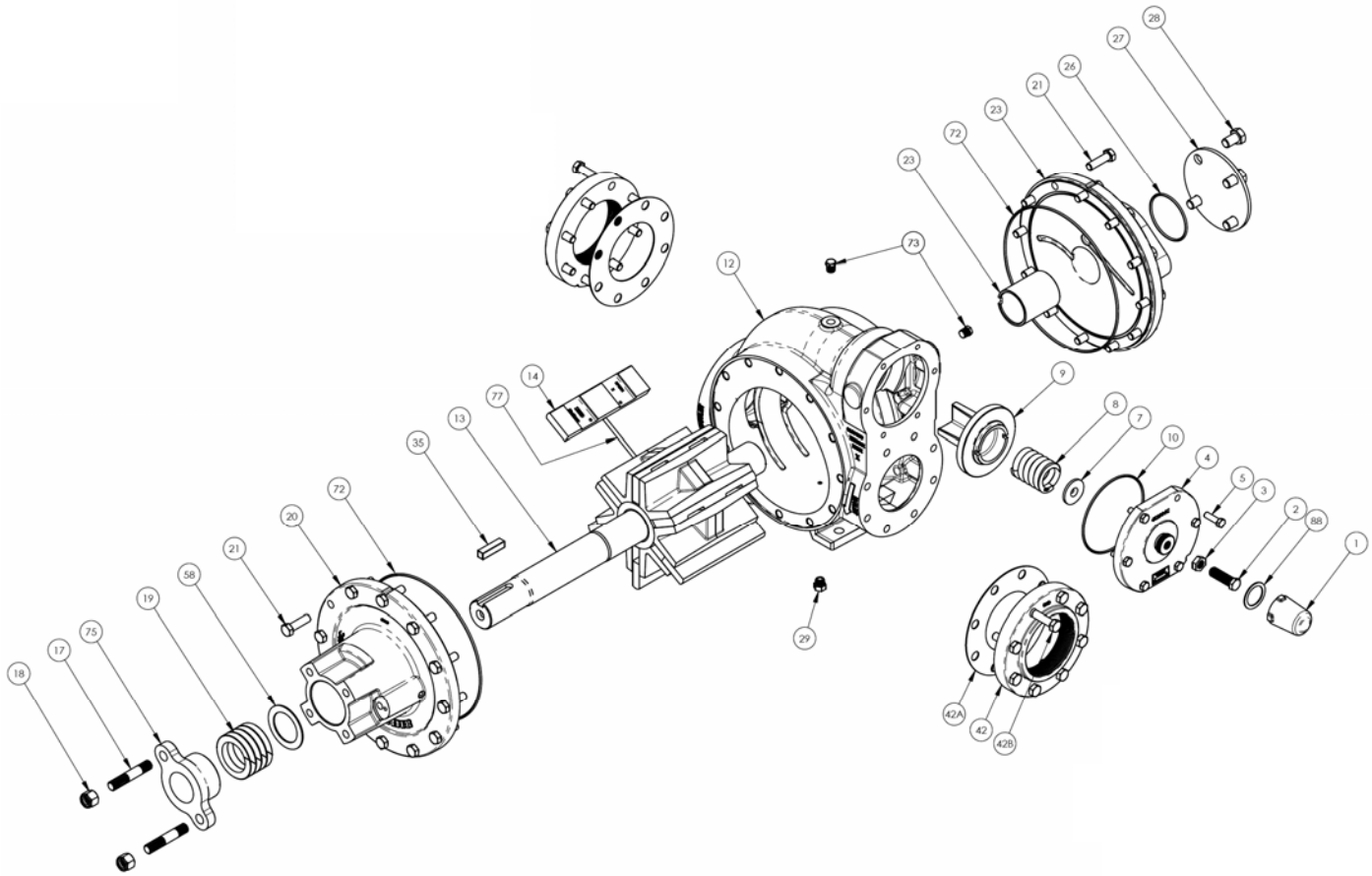

Ref. No.	Description	Parts per Pump	Part No.	Ref. No.	Description	Parts per Pump	Part No.
1	Cap - Relief Valve (R/V)	1	413957	20	Head & Bushing Asy. – Inboard (EH)	1	031984
2	Adjusting Screw - R/V (Std.)	1	436307	21	Capscrews - Head	24	920532
3	Locknut - Adjusting Screw	1	436355	23	Head & Bushing Asy. – Outboard (EH)	1	031985
4	Cover - R/V (Std.)	1	411968	24	Bushing (Sleeve Bearing) (EH)	2	161901
5	Capscrew - R/V Cover (Std.)	6	920351	26	O-Ring - Bearing Cover (FKM) (Std.)	1	702222
7	Spring Guide - R/V	1	426355		O-Ring - Bearing Cover (PTFE)		702225
8	SS Spring - R/V (51-75 psi)	1	476314	27	Bearing Cover	1	041900
	SS Spring - R/V (76-150 psi)		476321	28	Capscrews - Bearing Cover	4	920611
9	Valve - R/V (Std.)	1	456315	29	Pipe Plug Asy. (SAE # 6) (FKM) (Std.)	1	908212
	Valve - R/V (Nickel Plated)		456300		Pipe Plug Asy. (SAE # 6) (PTFE)		908213
10	O-Ring - R/V Cover (FKM) (Std.)	1	702229	35	Key - Shaft	1	909191
	O-Ring - R/V Cover (PTFE)		702230	42	See Page 4 for Flange Options		
12	Cylinder (Std.)	1	021915	72	O-Ring - Head (FKM) (Std.)	2	702128
	Cylinder w/ SAE Drain (Ductile Iron) <sup>4</sup>		021916		O-Ring - Head (PTFE)		702129
13	Rotor & Shaft, Open Rotor (Shown)	1	261968	73	Gage Plug	2	908198
	Rotor & Shaft, Closed Rotor (Optional)		261980	77	Push Rods	3	121905
14	Vane - Duravane (Std.) <sup>2</sup>	6	091924	88	Gasket – R/V Cap	1	533909
	Vane - EC Laminate		091931				
	Vane - EC Cast Iron		091952				
	Vane - EC Bronze		091953				

<sup>2</sup> 150 psi maximum for Duravanes

EH = Electric Heat Option    EC = Extra Clearance    SS = Stainless Steel



1809 Century Avenue, Grand Rapids, Michigan 49503-1530, U.S.A.  
 Telephone: (616) 241-1611 / Fax: (616) 241-3752  
 E-Mail: blackmer@blackmer.com / Internet: www.blackmer.com

Parts List 103-A06  
 Page 2 of 4

**PACKING - STANDARD & ELECTRIC HEAT OPTION**

Ref. No.	Part Name	Parts Per Pump	Part No.
17	Stud - Packing Follower	2	921610
18	Nut - Packing Follower Stud	2	922435
19	Packing Set (std) Packing Set (EH)	1	<sup>5</sup> 321968 321980
58	Pack Washer	1	351900
75	Packing Follower	1	141968

<sup>5</sup> Included in Maintenance Kit

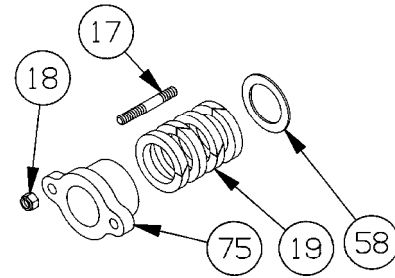

**LIP SEAL - OPTIONAL <sup>4</sup>**

Ref. No.	Part Name	Parts Per Pump	Part No.
16	Capscrew - Follower	2	920640
75	Seal Follower	1	141968
152	Lip Seal Assembly (To 500°F)	1	702246
152D	Wave Spring	1	321901

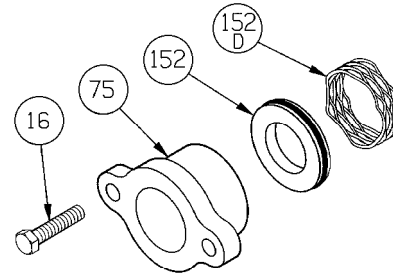

**NOTE:** A Commercial Mechanical Seal (cartridge type) may be used in place of packing or lip seals. Consult mechanical seal manufacturer for more information.

**COMMERCIAL MECHANICAL SEAL (Cartridge Type) - OPTIONAL**

Ref. No.	Part Name	Parts Per Pump	Part No.
-	John Crane 5610	1	331940

**NOTE:** Seal Materials (Sil-Car, Carbon, FKM)

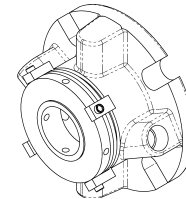

Commercial Mechanical Seal Cartridge Type

**TRIPLE-LIP CARTRIDGE SEAL - OPTIONAL**

Ref. No.	Part Name	Seal	Seal Rebuild Kit
—	<b>Triple-Lip Cartridge Seal</b>	<b>331948</b>	<b>899107</b>
220	Shaft Sleeve O-Ring	2	X
221	Shaft Sleeve	1	
222	Gasket	1	X
223	Gland Plate Assembly	1	
224	Element O-Ring	1	X
225	Seal Spacer	1	X
226	Seal Element	3	X
227	Flushing Spacer	1	X
228	Flushing Spacer O-Ring	1	X
229	Retaining Ring	1	
230	Snap Ring	1	X
231	Shaft Sleeve Setscrews	6	X
233	Gland Capscrew	4	
234	Flat Washer	4	

X = Parts Included in Seal Rebuild Kit

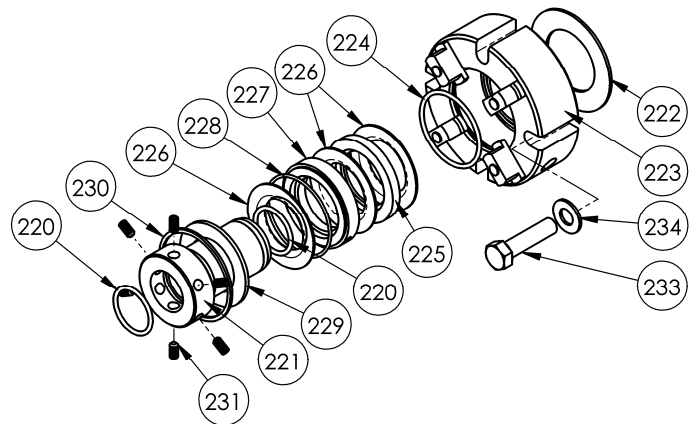

**FLANGE OPTIONS**

Ref. No.	Part Name	Parts Per Pump	Part No.
42	Flange - 4" NPT (Std.)	0 - 2	651900
	Flange - 4" Weld		651906
	Flange - ANSI 4" 150 lb. R.F.		651917
42A	Gasket - NPT Flange (Comp.) (Std.)	2	381904
42B	Capscrew	16	920532
42C	O-Ring - Flange (FKM)	0 - 2	702238
	O-Ring - Flange (PTFE)		702239
	O-Ring - Flange (Buna-N) <sup>4</sup>		702237

