

BLACKMER PUMP PARTS LIST

MODELS: LGL2C, TLGLD2C, LGL3C, TLGLD3C

(See Instructions 585/ZD for Operation and Maintenance)

960416
PARTS LIST NO. 585/ZD1

Section Effective Replaces | 500 January 1982 January 1980

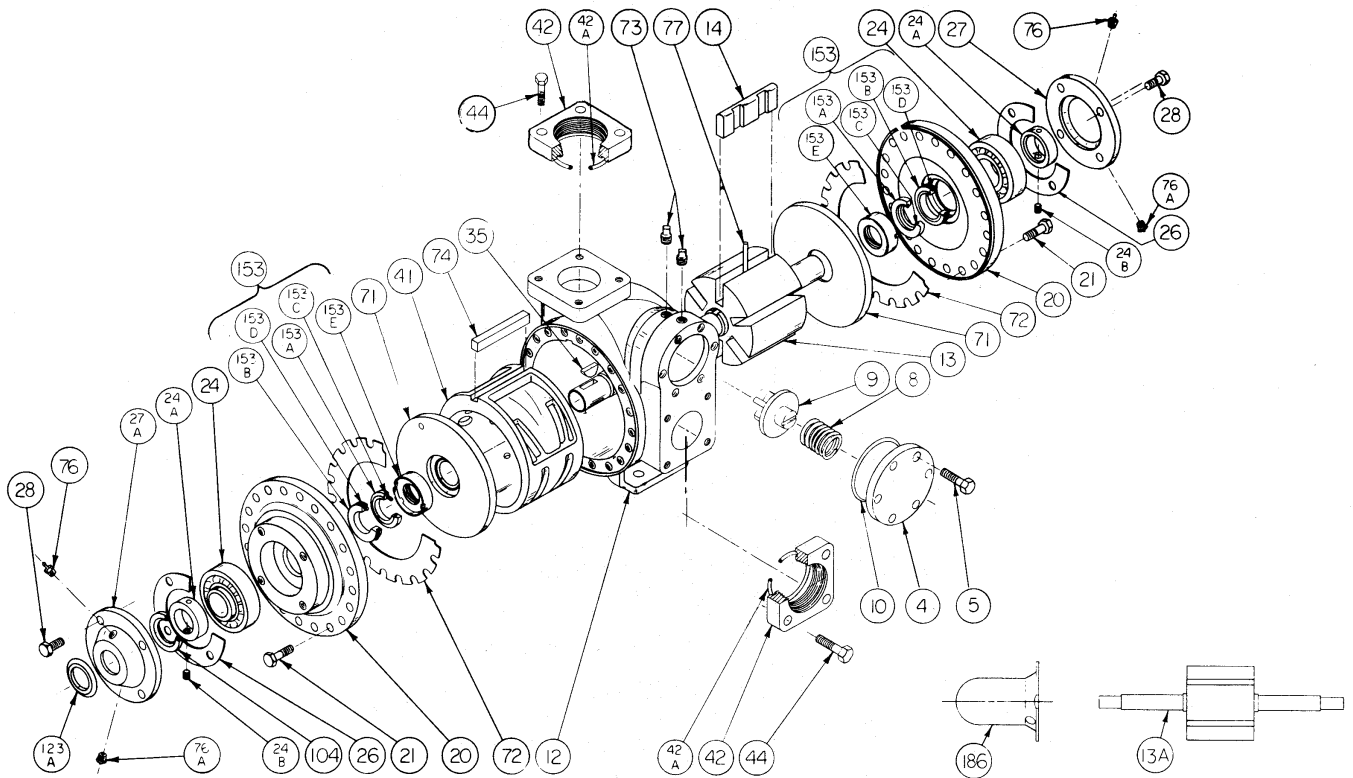

REF. NO.	PART NAME	NO. PARTS PER PUMP	Size 2 PART NO.	Size 3 PART NO.	REF. NO.	PART NAME	NO. PARTS PER PUMP	Size 2 PART NO.	Size 3 PART NO.
4	Valve Cover	1	414407	415111	76	Grease Fitting	2/set	317815	317815
5	Valve Cover Capscrews	6	920316	920331	76A	Grease Relief Fitting	2/set	701992	701992
8	Valve Spring	1	471428	471620	77	Push Rod	3	123905	125105
9	Relief Valve	1	454405	455129	104	Grease Seal	1(2)	331918	331908
10	"O" Ring, Valve Cover	1	701919	701925	123A	Dirt Shield	1(2)	701480	
12	Casing	1	014426	015126	MECHANICAL SEAL				
13	Rotor & Shaft	1	264400	265144	153	Mechanical Seal - Complete-Buna N	2	331417	331825
13A	Rotor & Double end shaft	1	264403	265146	153A	Seal Face - Carbon	2	331425	331812
14	Vane, Duravane	6	091419	095131	153B	Stationary Seat - Steel	2	334412	331828
20	Head	2	034417	035126	153C	"O" Ring, rotating-Buna N	2	711917	701926
21	Head Capscrew	32-40	920351	920369	153D	"O" Ring, stationary-Buna N	2	711916	711924
24	Bearing	2	903154	903168	153E	Seal Jacket Assembly	2	331416	331804
24A	Bearing Lockcollar	2	701409	705110	MECHANICAL SEAL - MAPP Gas				
24B	Lockcollar Setscrew	2	922178	922178	153	Mechanical Seal Assembly	2	331453	331853
26	Bearing Cover Gasket	2	383940	385125	153A	Seal Face - Carbon	2	331425	331812
27	Bearing Cover-outboard	1(3)	041433	041817	153B	Stationary Seat - Steel	2	334412	331828
27A	Bearing Cover-inboard	1(2)	041431	041815	153C	"O" Ring, rotating-Viton	2	701979	701982
28	Bearing Cover Capscrew	8-12	920285	920285	153D	"O" Ring, stationary-Viton	2	711908	701970
35	Shaft Key	1	909130	909130	153E	Seal Jacket Assembly	2	331416	331804
41	Liner	1	184405	185111	186	Shaft Protector	1(1)	341601	
42	NPT Flange	2	654401	655112		Pump Repair Kit		894421	895122
	Weld Flange	2	654405	655102					
42A	"O" Ring	2	702004	702002					
44	Capscrew-NPT Flange	8	920351	920532					
	Capscrew-Weld Flange	8	920351	920510					
71	Disc	2	064413	065113					
72	Head Gasket	2	383935	385107					
73	Gage Plug	2	908195	908195					
74	Liner Key	1	183991	185191					

The following are for TLGLD2: (1) use one(1), (2) use two(2), (3) use none(0).

DISCONTINUED MODELS

PUMP DIMENSIONS

Right Hand pump shown. Shaft projection is opposite for Left Hand pump.

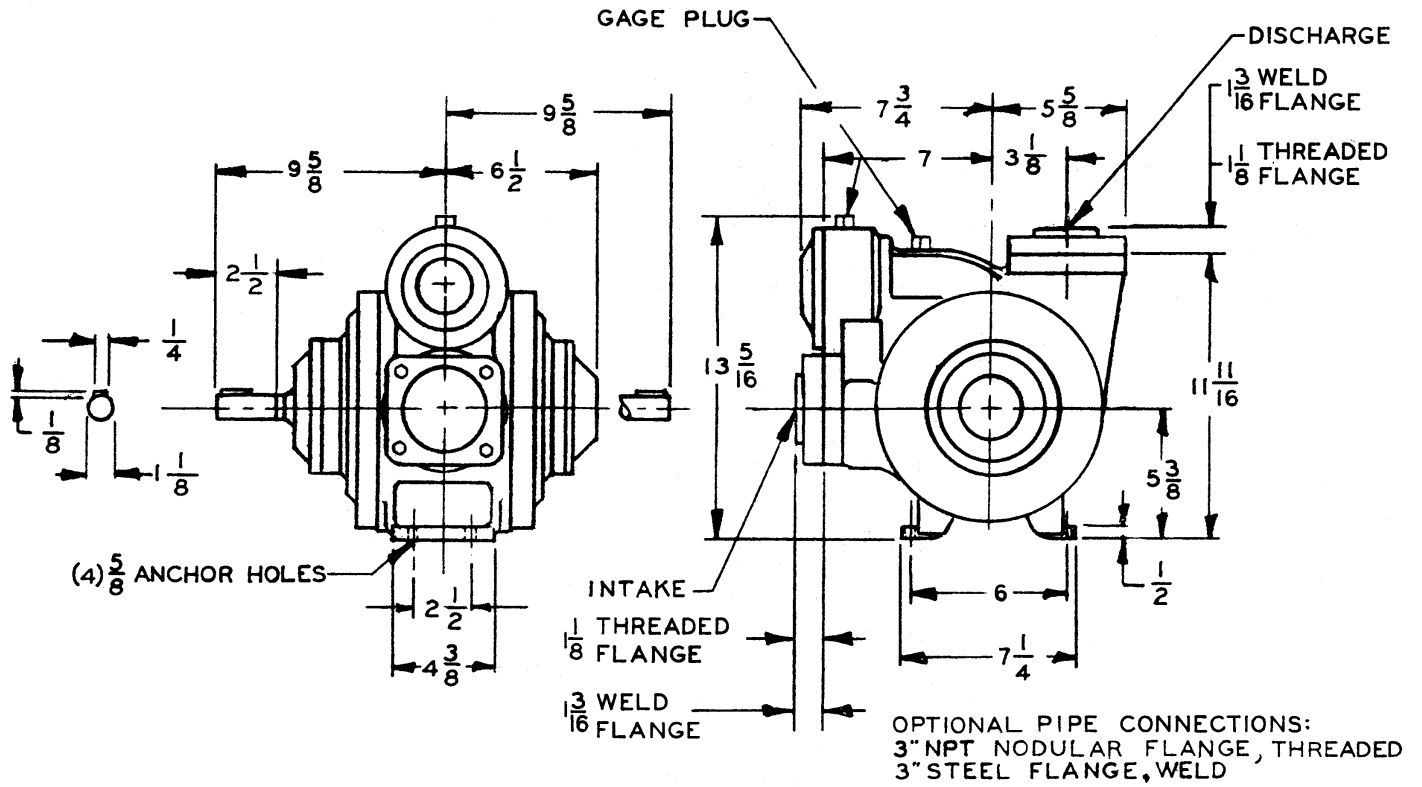

Fig. 1 - Mounting Dimensions 3" Pump

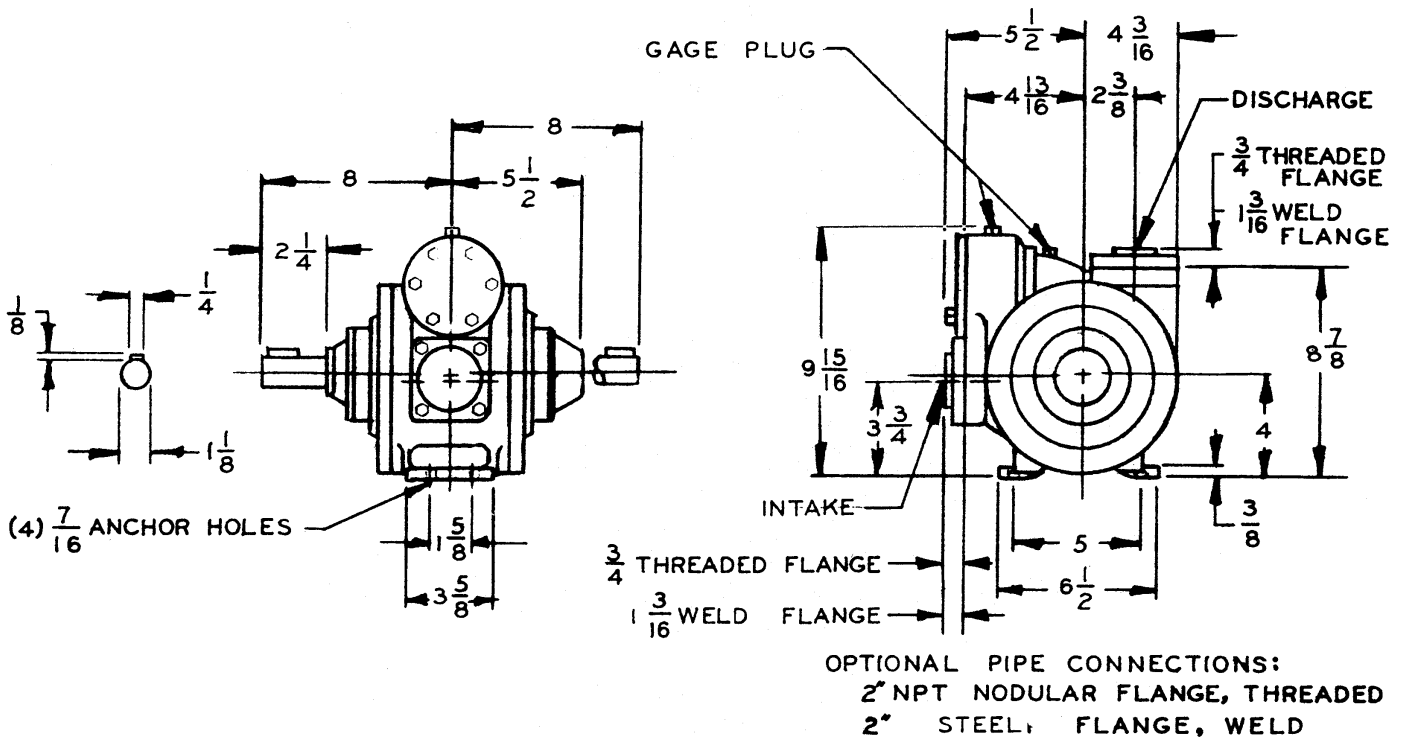

Fig. 2 - Mounting Dimensions 2" Pump

blackmer / A **DOVER** COMPANY

1809 Century Avenue, Grand Rapids, Michigan 49503, U.S.A. • (616) 241-1611 • Telex: 4320148 • Fax: (616) 241-3752