

# BLACKMER DIFFERENTIAL BYPASS VALVES

## MODEL: BV2A

DISCONTINUED MODEL BV2

PARTS LIST WITH INSTALLATION AND OPERATION INSTRUCTIONS

960452  
Page 1 of 4

**PARTS LIST**  
**505-A03**

Section	505
Effective	Aug 2015
Replaces	July 2013

### PARTS LIST

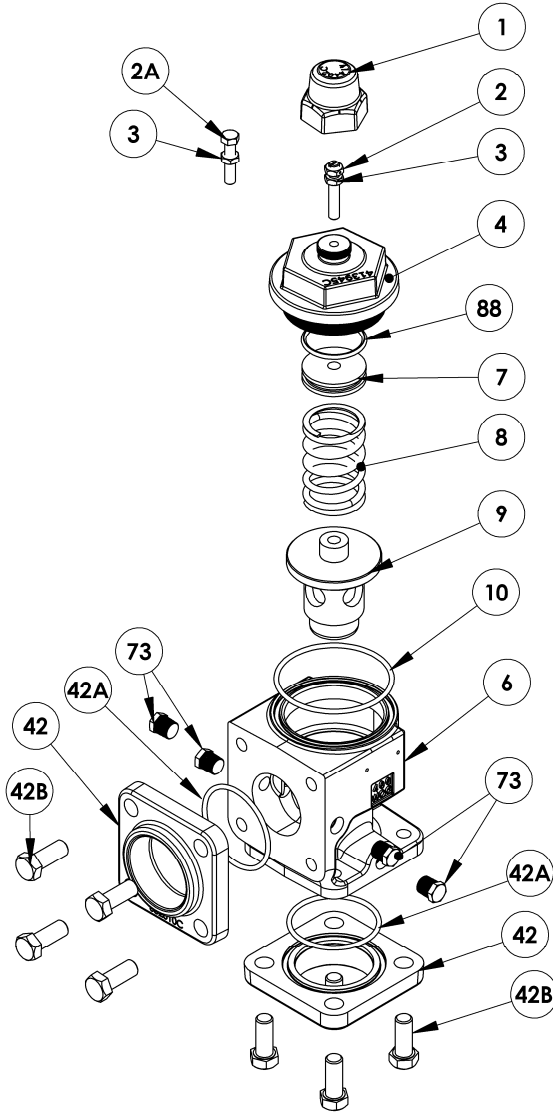

Ref. No.	Description	Parts Per Unit	Part No.
1	Cap	1	414402
2	Adjusting Stud & Nut Asy. (91-125 psi) (std)	1	*
2A	Adjusting Screw (20 - 40 psi)	1	437803
	Adjusting Screw (41 - 70 psi)		437803
	Adjusting Screw (71 - 90 psi)		437803
	Adjusting Screw (126 - 150 psi)		433905
3	Locknut	1	922923
4	Cover	1	413945
6	Body	1	403945
7	Spring Guide	1	423953
8	Spring (20 - 40 psi)	1	471803
	Spring (41 - 70 psi)		471805
	SS Spring (41 - 70 psi) <sup>1,3</sup>		471815
	Spring (71 - 90 psi)		471811
	Spring (91 - 125 psi) (Std.)		471806
	Spring (126 - 150 psi)		471810
9	Valve (with pressure equalizing hole)	1	453942
10	O-Ring - Cover (Buna-N) (Std.)	1	701916
	O-Ring - Cover (FKM) <sup>1,3</sup>		711959
42	Flange - 2" NPT (Std.)	2	652010
	Flange - 2" Slip-on Weld **		652024
	Flange - 2" Socket Weld EI		655109
	Flange - 1.25" NPT		652029
	Flange - 1.5" NPT		652028
	Flange - 1.25" Slip-on Weld		652027
	Flange - 1.5" Slip-on Weld		652026
42A	O-Ring - Flange (Buna-N) (Std.) **	2	702004
	O-Ring - Flange (FKM) <sup>1,3</sup>		702086
42B	Capscrews - Flange	8	920491
73	Pipe Plug - 1/4" NPT	4	908198
88	O-Ring Spring Guide (Buna-N)	1	711916
	O-Ring - Spring Guide (FKM) <sup>1,3</sup>		711908

\* Assembly is not a saleable part; preset at factory.

\*\* Weld Flange O-rings before Nov 2002: 701919 Buna-N, 711929 FKM<sup>1</sup>

<sup>1</sup> Not-U.L. Listed.

<sup>3</sup> For MAPP Gas; use FKM O-rings and SS spring together.

## DIMENSIONS

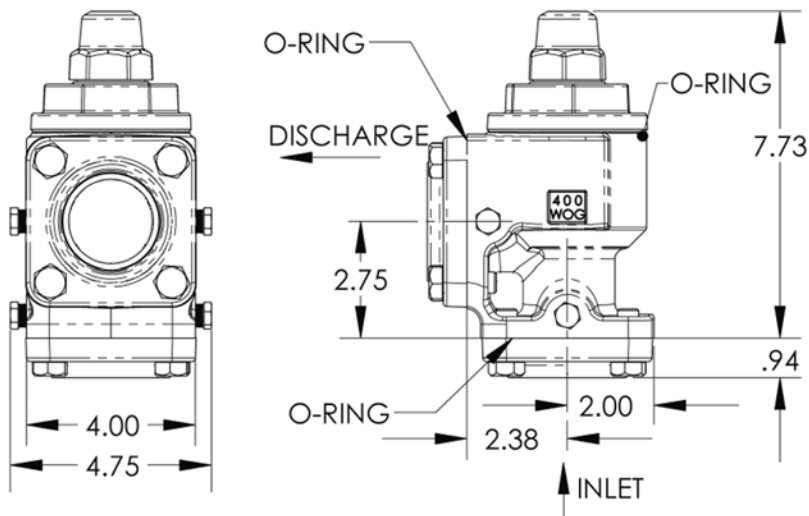

### CAUTION

**Bypass valve with welded connections**  
**The bypass valve contains three O-ring seals that will be damaged if welding is done with these O-rings installed.**

Prior to welding the piping, remove the O-rings from the inlet and outlet flanges and the bypass cover (see Figure 1). Reinstall the inlet and outlet flanges and weld the piping. Then reinstall the three O-rings.

## INSTALLATION AND OPERATION

### NOTICE

Blackmer bypass valves **must** only be installed in LPG & NH<sub>3</sub> systems that have been designed by qualified engineering personnel and operated and maintained by qualified technicians. The system **must** conform to all applicable local and national regulations and safety standards (specifically, LPG systems **must** conform to NFPA 58). This manual **must** be kept with the bypass valve and be reviewed **before** installation, putting into operation or performing any maintenance work.

### WARNING



Hazardous pressure can cause personal injury or property damage

**Do not attempt to open the pump or external bypass valve until you have bled off the pressure. On systems with meters, the differential valve will keep liquid under pressure in the pump, meter and piping even when the hose is emptied.**

### INSTALLATION

On liquefied gas systems, an external bypass valve, piped back to the supply tank, is necessary for maximum pump performance and longer pump life. The bypass valve must be installed in the correct position on the discharge side of the pump. (An arrow cast on the valve body indicates intake and discharge.) The bypass valve will automatically prevent excessive pressure resulting from accidental pump overspeeding, discharge shut-off, or highly restrictive receiving systems.

Size the external bypass valve and its piping to accommodate the full flow from the pump when the pump's discharge line is closed and the pump is running at its rated maximum speed.

When installing the external bypass valve, it is essential that the pipe and fittings from the discharge port of the bypass valve be sized properly. Excessive back pressure resulting from friction loss in the bypass valve discharge piping will cause a higher pressure than the actual bypass valve setting.

For example, a BV2A bypass valve has a characteristic pressure when set at 90 psi (6.21 bar) as shown on the following curve. If the friction loss through the bypass valve,

discharge pipe and fittings (pipe, elbows, tees, shut-off valve, check valve, etc.) is 12 psi (.84 bar) at 100 gpm (379 lpm) flow rate, then the actual differential pressure in the system will rise under bypass conditions, as illustrated on the curve.

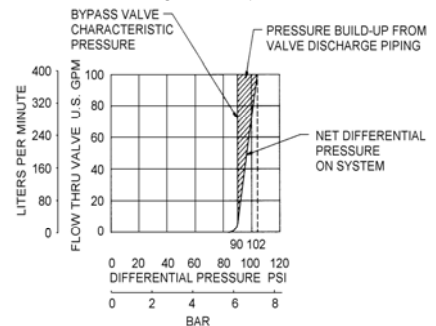

For more information on sizing and friction loss, refer to the Blackmer Liquefied Gas Handbook - Bulletin 500-001 (or Bulletin 33 for other liquids) for pipe friction tables.

On liquefied gas systems, the external bypass valve discharge must be piped back to the liquid or vapor section of the supply tank never to the pump inlet. This method of piping should also be used when pumping volatile liquids from an underground tank or at high vacuum.

### FLOW RATING - BV2A

Liquid Viscosity	*Normal Maximum Rated Flow - GPM (LPM)			
	at 20 psi (1.38 bar)	at 50 psi (3.45 bar)	at 80 psi (5.52 bar)	at 120 psi (8.27 bar)
100 SSU (22 Cs) - Propane, Gasoline	150 (568)	180 (681)	220 (833)	250 (946)
500 SSU (105 Cs)	120 (454)	150 (568)	180 (681)	210 (795)
1000 SSU (220 Cs)	100 (379)	135 (511)	165 (625)	195 (738)
3000 SSU (630 Cs)	80 (303)	120 (454)	150 (568)	180 (681)
5000 SSU (1050 Cs)	60 (227)	100 (379)	130 (492)	160 (606)

\* This is the maximum flow that will pass through the external bypass valve without an increase in pressure over the valve differential pressure setting.



## OPERATION

Unless otherwise specified, the standard BV2A external bypass valves are factory set at 125 psi (8.62 bar) differential pressure for LP-Gas and NH<sub>3</sub> service, per Underwriters Laboratories. Optional spring ranges are available.

Pressure Equipment Directive design life expectancy is 10 years.

### NOTICE:

**At temperatures below -20° F (-28.9° C) materials have reduced impact strength. Provisions should be made to prevent tools and other objects from impacting any pressure containing components of the pumping system.**

**Annual inspection and testing of the internal relief valve (if applicable) and the external bypass valve operation and setting is recommended.**

To check the pump's internal relief valve setting and the external bypass valve setting, follow these steps:

1. Install a pressure gauge equipped with a needle valve or snubber in the pump discharge gauge port. Install a pressure gauge on the tank and record the tank pressure.
2. Connect the delivery hose to the receiving tank.
3. Check all valves. The shut-off valve in the pump's discharge line, and the shut-off valve in the external bypass return line should be open.
4. Start pumping at the normal rate. Make sure the supply tank outlet valve is wide open and check the direction of shaft rotation to be sure it matches the direction of the arrow on the pump.
5. Check the pressure setting of the pump's internal relief valve (when applicable) with the following procedure:

First gradually close the shut-off valve in the external bypass return line.

Then slowly close the shut-off valve in the pump's discharge line while watching the gauge pressure on the discharge side of the pump. Record the peak differential pressure (the difference between the discharge and inlet pressure) when the internal relief valve begins to open. NOTE: It is important to read the peak pressure just before the pump relief valve opens. Once recirculation starts through the internal relief valve, vaporization will cause the pressure to fall quickly. For more information on the relief valve settings and adjustments, refer to the installation instructions for the specific pump.

6. After the internal relief valve setting has been determined, reopen the shut-off valve in the pump's discharge line and the shut-off valve in the external bypass return line. Continue pumping at the normal rate.

7. To check the external bypass valve setting, gradually close the shut-off valve in the pump's discharge line and record the gauge pressure. The difference between this reading and the tank pressure (before pumping) is the external bypass valve setting.

The external bypass valve must be set at least 25 psi (1.72 bar) less than the pump's internal relief valve setting. This pressure setting will ensure that the liquid does not recirculate through the relief valve, and thus cause excessive pump wear and noise.

Reopen the shut-off valve in the pump's discharge line and resume normal pumping operation. Record the discharge gauge pressure. The difference between this reading and the tank pressure (before pumping) is the normal system operating pressure.

If possible\*, the external bypass valve setting should also be at least 15 psi (1.03 bar) higher than the normal system operating pressure. Operating pressures nearing the external bypass valve setting may mean liquid is being recirculated unnecessarily. \*A lower external bypass valve setting may be necessary with smaller motors.

If necessary, adjustment to the external bypass valve can be made by removing the valve cap and loosening the locknut.

**WARNING: Do not remove the valve cap on the external bypass valve until you have bled off the pressure.** To increase the pressure setting, turn the adjusting stud and nut assembly (or adjusting screw) inward, or clockwise. To reduce the pressure setting, turn the adjusting stud and nut assembly (or adjusting screw) outward, or counterclockwise.



Blank page



1809 Century Avenue, Grand Rapids, Michigan 49503-1530, U.S.A.  
Telephone: (616) 241-1611 / Fax: (616) 241-3752  
E-Mail: [blackmer@blackmer.com](mailto:blackmer@blackmer.com) / Internet: [www.blackmer.com](http://www.blackmer.com)

Parts List 505-A03  
Page 4 of 4