

TYPE	SIZE	UNIT STYLE
TXH	3	PO

DIMENSIONS 201-117	
Section Effective Replaces Page 1 / 1	200 August 2011 December 2008

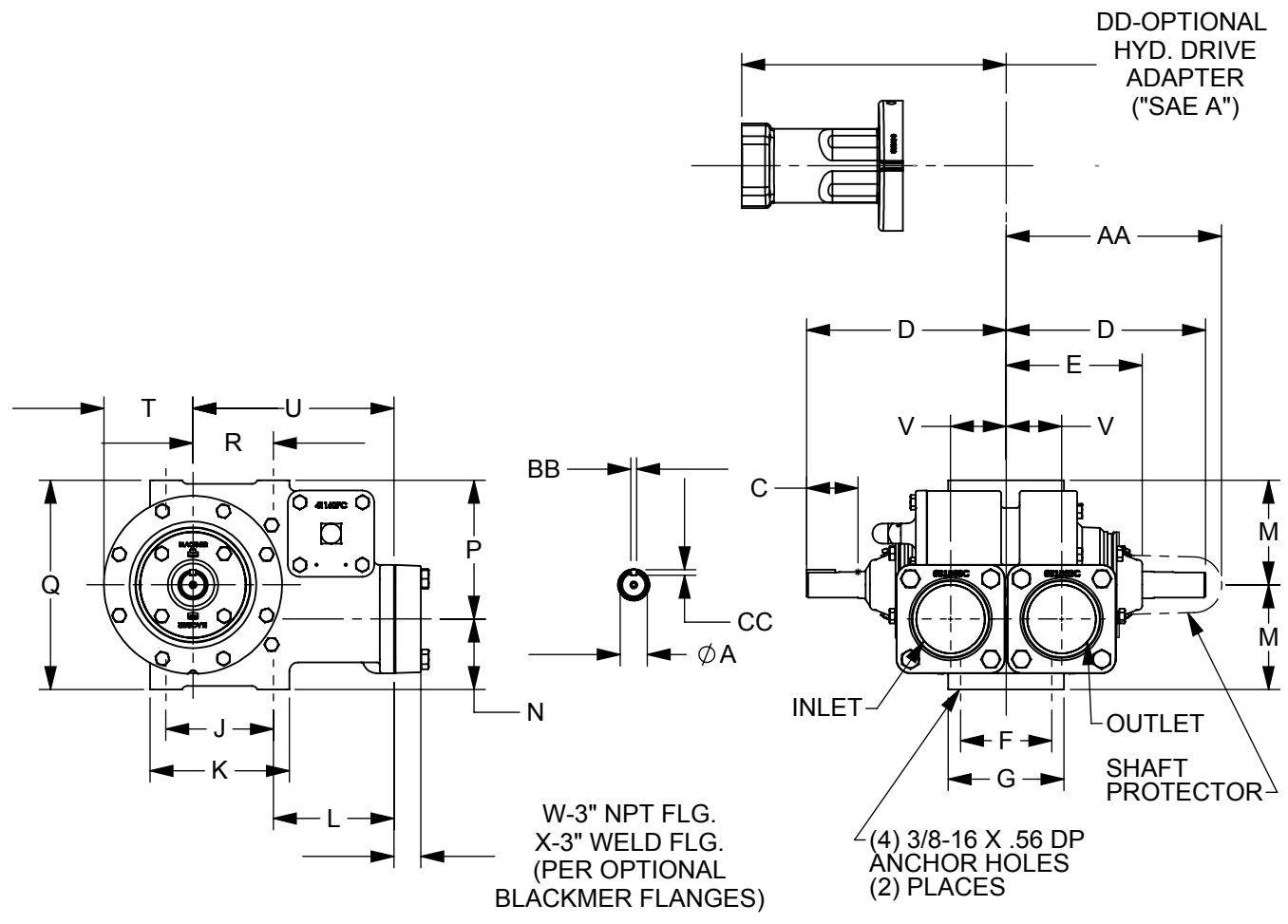

RIGHT HAND ROTATION. FOR LEFT HAND ROTATION SHAFT PROJECTION IS OPPOSITE THAT SHOWN

MOTOR		UNITS	DIMENSIONS									
FRAME SIZE			A	B	C	D	E	F	G	H	J	K
		IN	1 1/8	-	2 1/4	8 3/4	6	4	5 1/4	-	4 23/32	6 1/8
		MM	28,6	-	57,2	222,3	152,4	101,6	133,4	-	119,86	155,58
			L	M	N	P	Q	R	S	T	U	V
		IN	5 5/16	4 19/32	3 3/32	6 3/32	9 3/16	3 1/2	-	3 7/8	8 13/16	2 7/16
		MM	134,88	116,59	79,5	154,7	233,36	88,9	-	98,43	223,82	62
			W	X	Y	Z	AA	BB	CC	DD		
		IN	1 1/8	1 3/16	-	-	9 1/2	1/4	7/64			
		MM	28,45	30,23	-	-	241,3	6,4	2,8			
			PUMP WEIGHT		WITH STD FLANGES						1 1/4" Hyd Motor Shaft	1" Hyd Motor Shaft
			LBS		99					IN	11 5/8	11 3/8
			KG		45					MM	295,3	289