

DIMENSIONS 106-103

Section 106
 Effective August 2005
 Replaces May 1988

TYPE

SIZE

UNIT
 STYLE

MLN, MRLN

4B

PO



www.blackmer.com

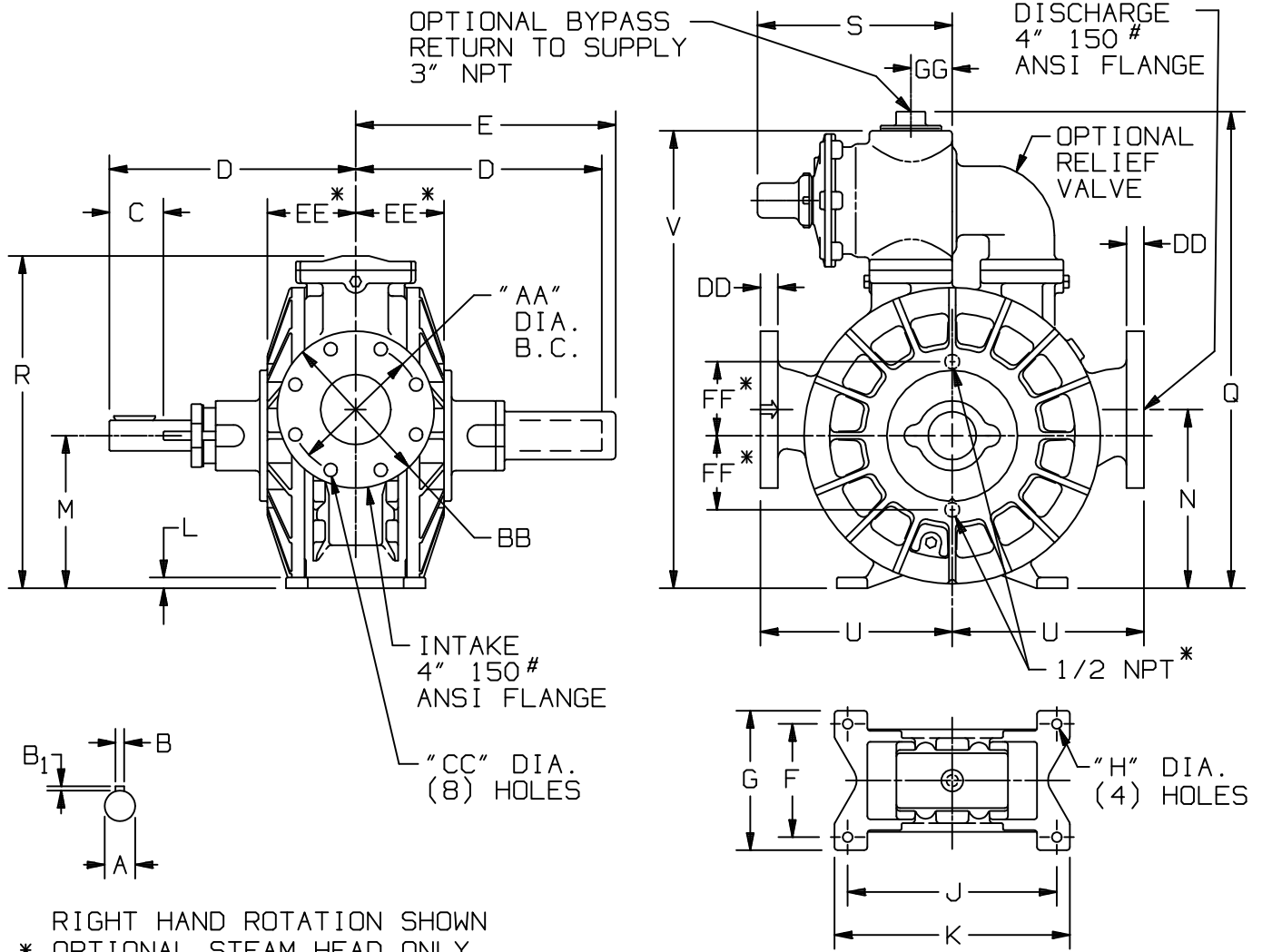

MOTOR		UNITS	DIMENSIONS										
FRAME SIZE			A	B	B ₁	C	D	E	F	G	H	J	
		IN	1 3/4	3/8	3/16	3 1/16	14 1/8	15 1/4	6 1/2	8	5/8	12	
		MM	44,4	9,5	4,8	77,8	358,8	387,4	165,1	203,2	15,9	304,8	
			K	L	M	N	P	Q	R	S	T	U	
		IN	13 1/2	11/16	8 3/4	10 1/4	—	27 3/8	19 1/16	11 1/4	—	11	
		MM	342,9	17,4	222,2	260,4	—	695,3	484,2	285,8	—	279,4	
			V	W	X	Y	Z	AA	BB	CC	DD	EE	
		IN	26 1/4	—	—	—	—	7 1/2	9	3/4	15/16	5 1/16	
		MM	666,8	—	—	—	—	190,5	228,6	19,1	23,8	128,6	
			FF	GG							APPROX WEIGHT	LESS RELIEF VALVE	
		IN	4 1/4	2 3/8							LBS	437	385
		MM	108	60,3							KG	19,7	17,3