

Blackmer

www.blackmer.com

TYPE	SIZE	UNIT STYLE	DIMENSIONS 106-101	
MLX, MRLX, MRLXW	4B	PO	Section Effective	106 August 2005
			Replaces	May 1988

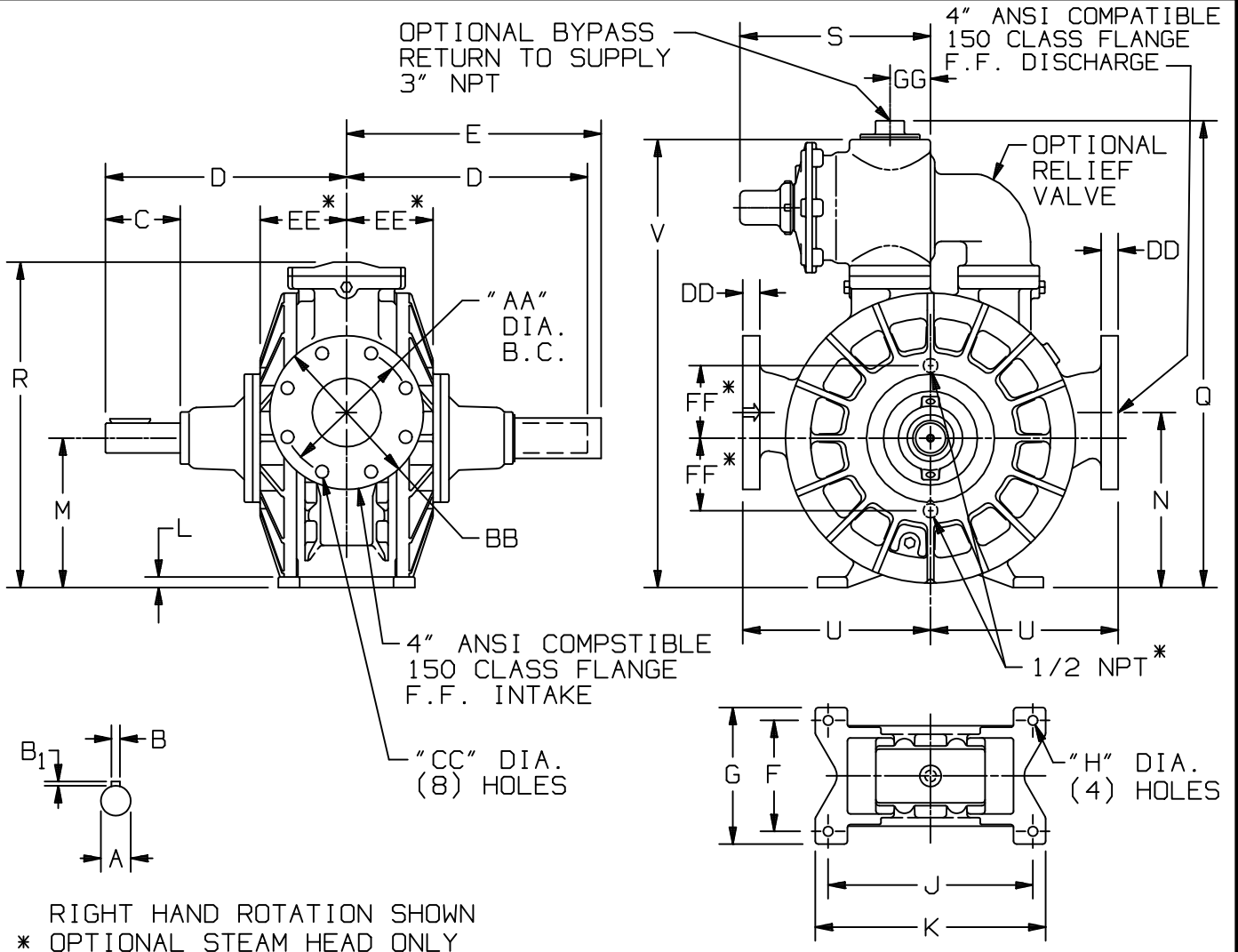

MOTOR			UNITS	DIMENSIONS									
FRAME SIZE				A	B	B ₁	C	D	E	F	G	H	J
			IN	1 3/4	3/8	3/16	4 3/8	14 1/8	15	6 1/2	8	5/8	12
			MM	44,4	9,5	4,8	111,1	358,8	381	165,1	203,2	15,9	304,8
				K	L	M	N	P	Q	R	S	T	U
			IN	13 1/2	11/16	8 3/4	10 1/4	—	27 3/8	19 1/16	11 1/4	—	11
			MM	342,9	17,4	222,2	260,4	—	695,3	484,2	285,8	—	279,4
				V	W	X	Y	Z	AA	BB	CC	DD	EE
			IN	26 1/4	—	—	—	—	7 1/2	9	3/4	15/16	5 1/16
			MM	666,8	—	—	—	—	190,5	228,6	19,1	23,8	128,6
				FF	GG							APPROX WEIGHT	LESS RELIEF VALVE
			IN	4 1/4	2 3/8						LBS	445	393
			MM	108	60,3						KG	202	179