



www.blackmer.com

TYPE

SIZE

UNIT  
STYLE

NP

3F

PO

DIMENSIONS 103-109

Section 100  
Effective November 2001  
Replaces April 1993  
Page 1/5

RIGHT HAND ROTATION. FOR LEFT HAND ROTATION, SHAFT PROJECTION IS OPPOSITE THAT SHOWN.

\* TOLERANCE  $\pm \frac{1}{8}$

TOLERANCE ON OTHER DIMENSIONS  $\pm \frac{1}{4}$

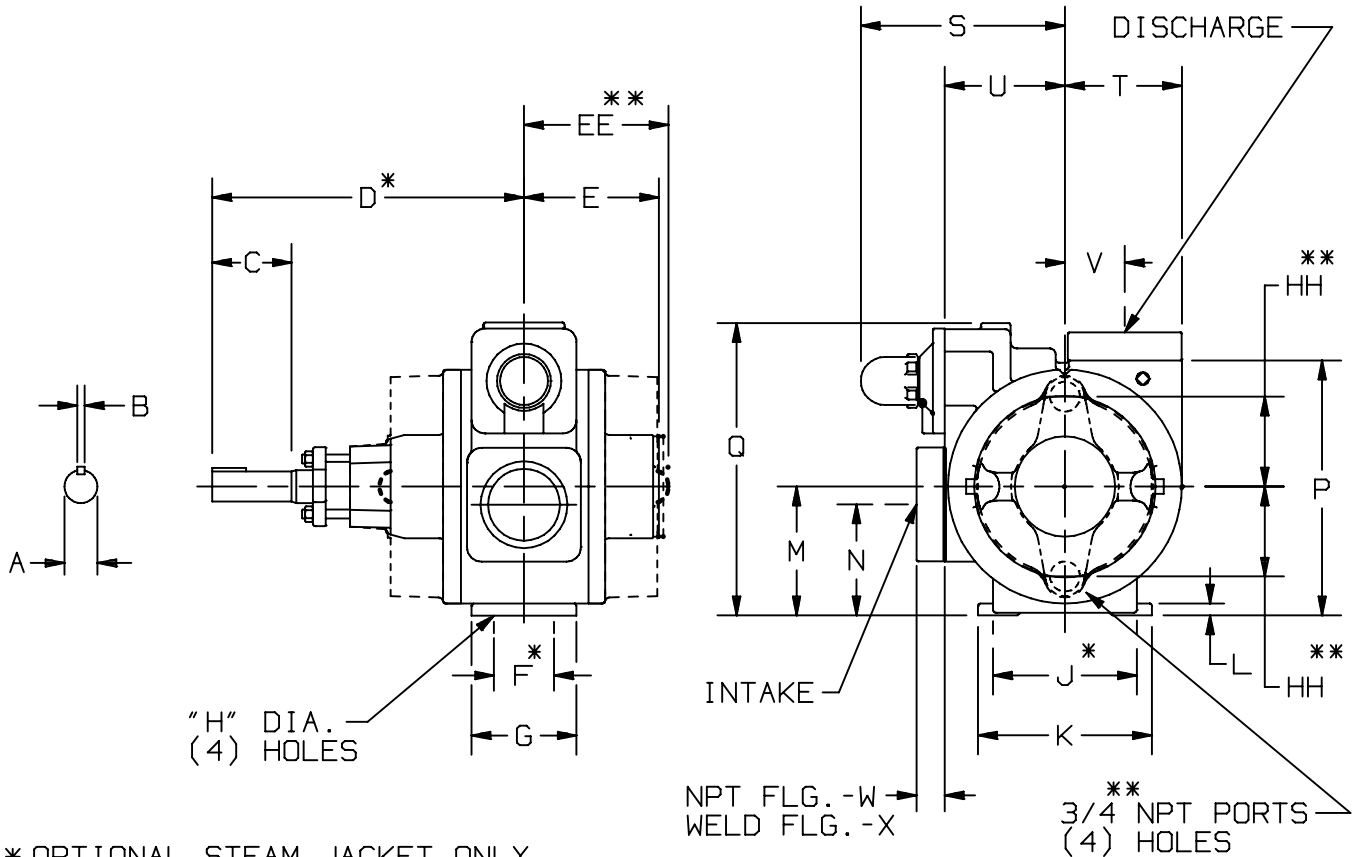

\*\* OPTIONAL STEAM JACKET ONLY

MOTOR			UNITS	DIMENSIONS									
FRAME SIZE				A	B	C	D	E	F	G	H	J	K
			IN	1 1/4	1/4	3 5/16	13	5 5/8	2 1/2	4 3/8	5/8	6	7 1/4
			MM	31,8	6,4	84,1	330,2	142,9	63,5	111,1	15,9	152,4	184,2
				L	M	N	P	Q	R	S	T	U	V
			IN	1/2	5 3/8	4 5/8	10 5/8	12 1/4	—	8 9/16	4 7/8	5	2 1/2
			MM	12,7	136,6	117,5	269,9	311,2	—	217,5	123,8	127	63,5
				W	X	Y	Z	AA	BB	CC	DD	EE	FF
			IN	1 1/8	1 1/4	—	—	—	—	—	15	6 1/8	—
			MM	28,6	31,8	—	—	—	—	—	381	155,7	—
				GG	HH					PUMP WEIGHT	WITH STD. FLANGES	** WITH JACKETED HEADS	
			IN	—	3 3/4					LBS	134	158	
			MM	—	92,3					KG	61	71,7	

NOTE: FOR ANSI AND DIN FLANGE DIMENSIONS, SEE DIMENSION SHEET 103-115

# Blackmer

www.blackmer.com

TYPE	SIZE	UNIT STYLE
NP	3	HRA

**DIMENSIONS 103-109**

Section	100
Effective	November 2001
Replaces	November 2000
Page	2/5

RIGHT HAND ROTATION

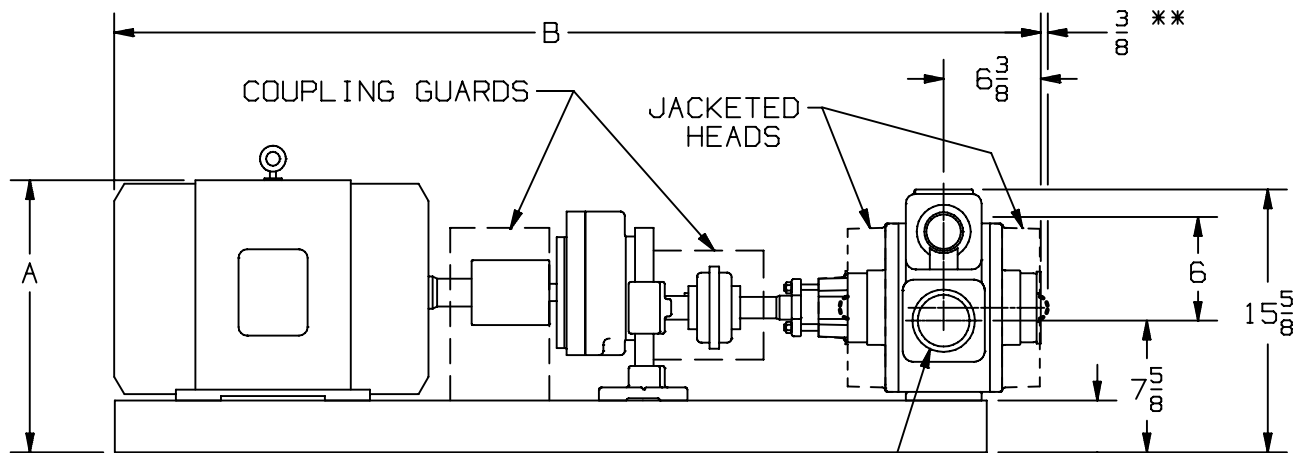
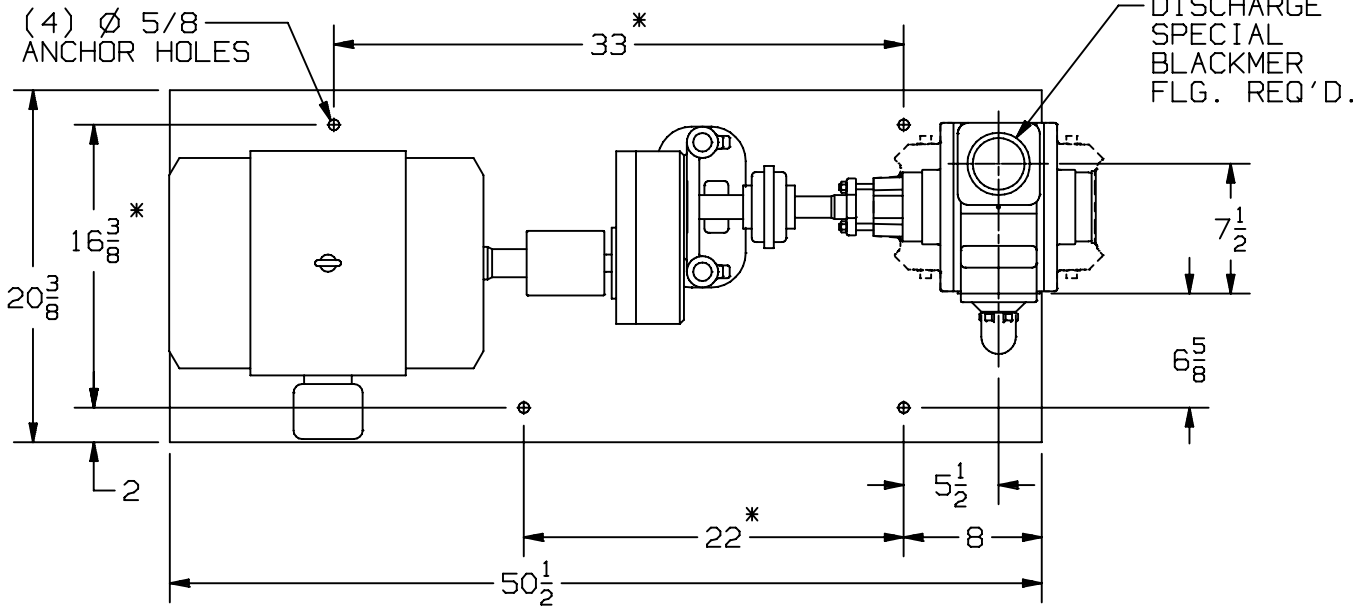

UNIT DIMENSION LESS FLANGES

\* TOLERANCE  $\pm \frac{1}{8}$

TOLERANCE ON OTHER DIMENSIONS  $\pm \frac{1}{4}$

"A" DIMENSION LESS EYEBOLT

\*\* FOR JACKETED HEADS

INTAKE SPECIAL BLACKMER FLG. REQ'D

FLG. HT: 3 NPT - 1 1/8  
3 WELD - 1 1/4

MOTOR		BASE NO.	DIMENSIONS							APPROX UNIT WT-POUNDS	
FRAME SIZE			UNITS	A	B					LESS MOTOR	ENCL MOTOR
182T		901684		12 5/8	55 1/8						
184T		901684		12 5/8	55 1/8						
213T		901684		14 1/8	55 1/8						
215T		901684		14 1/8	55 1/8						
254T		901684		16 3/8	56 3/8						
256T		901684		16 3/8	58 1/8						

DIMENSIONS 103-109

Section 100  
 Effective November 2001  
 Replaces November 2000  
 Page 3/5

TYPE	SIZE	UNIT STYLE
NP	3	HRA



www.blackmer.com

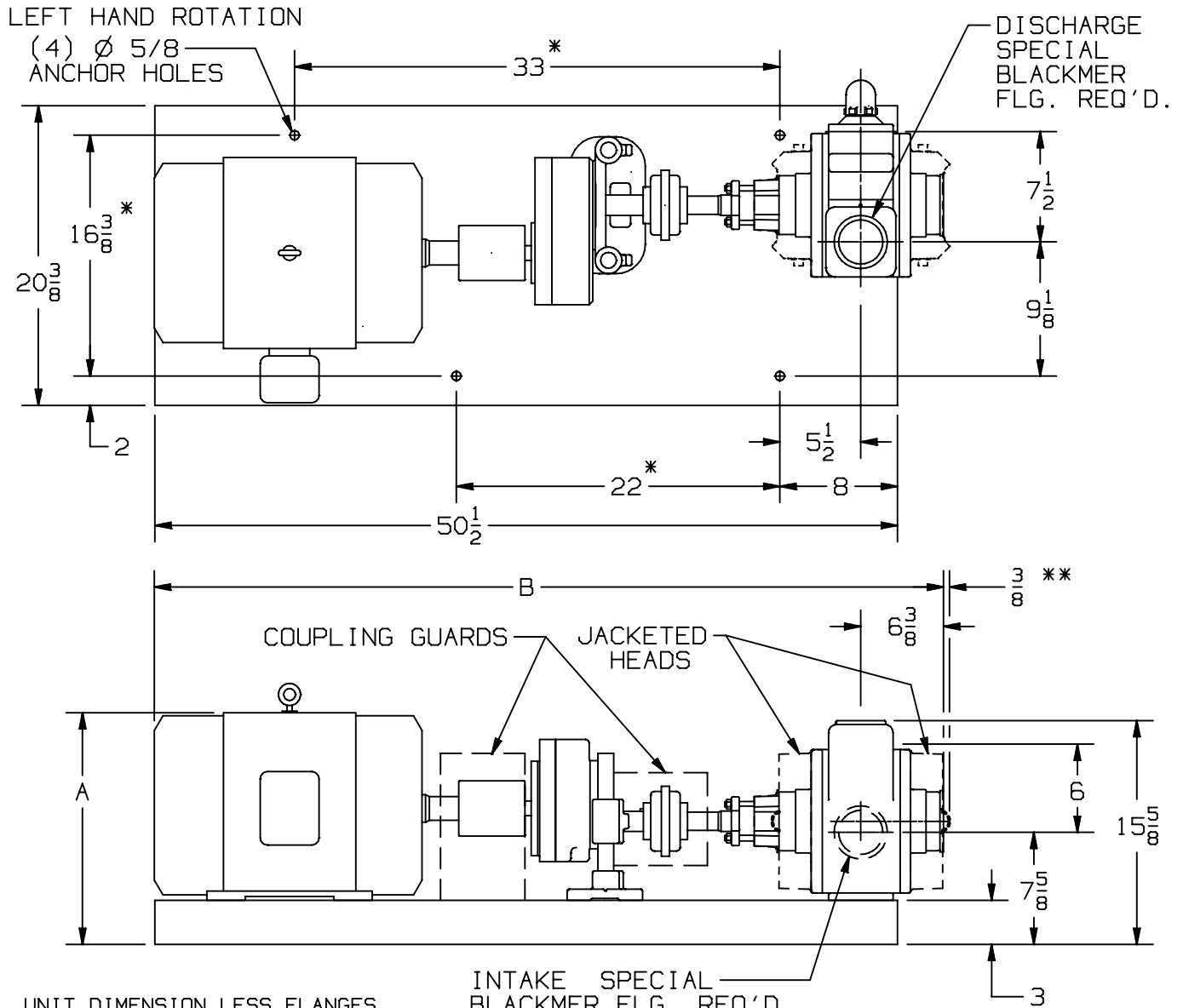

UNIT DIMENSION LESS FLANGES  
 \* TOLERANCE ± 1/8  
 TOLERANCE ON OTHER DIMENSIONS ± 1/4  
 "A" DIMENSION LESS EYEBOLT  
 \*\* FOR JACKETED HEADS

FLG. HT: 3 NPT - 1 1/8  
 3 WELD - 1 1/4

MOTOR		BASE NO.	DIMENSIONS						APPROX UNIT WT-POUNDS	
FRAME SIZE			UNITS	A	B				LESS MOTOR	ENCL MOTOR
182T		901684		12 5/8	55 1/8					
184T		901684		12 5/8	55 1/8					
213T		901684		14 1/8	55 1/8					
215T		901684		14 1/8	55 1/8					
254T		901684		16 3/8	56 3/8					
256T		901684		16 3/8	58 1/8					



www.blackmer.com

TYPE	SIZE	UNIT STYLE
NP	3	HRB

DIMENSIONS 103-109

Section Effective	103 March 2006
Replaces	November 2001
Page 4/5	

RIGHT HAND ROTATION SHOWN.

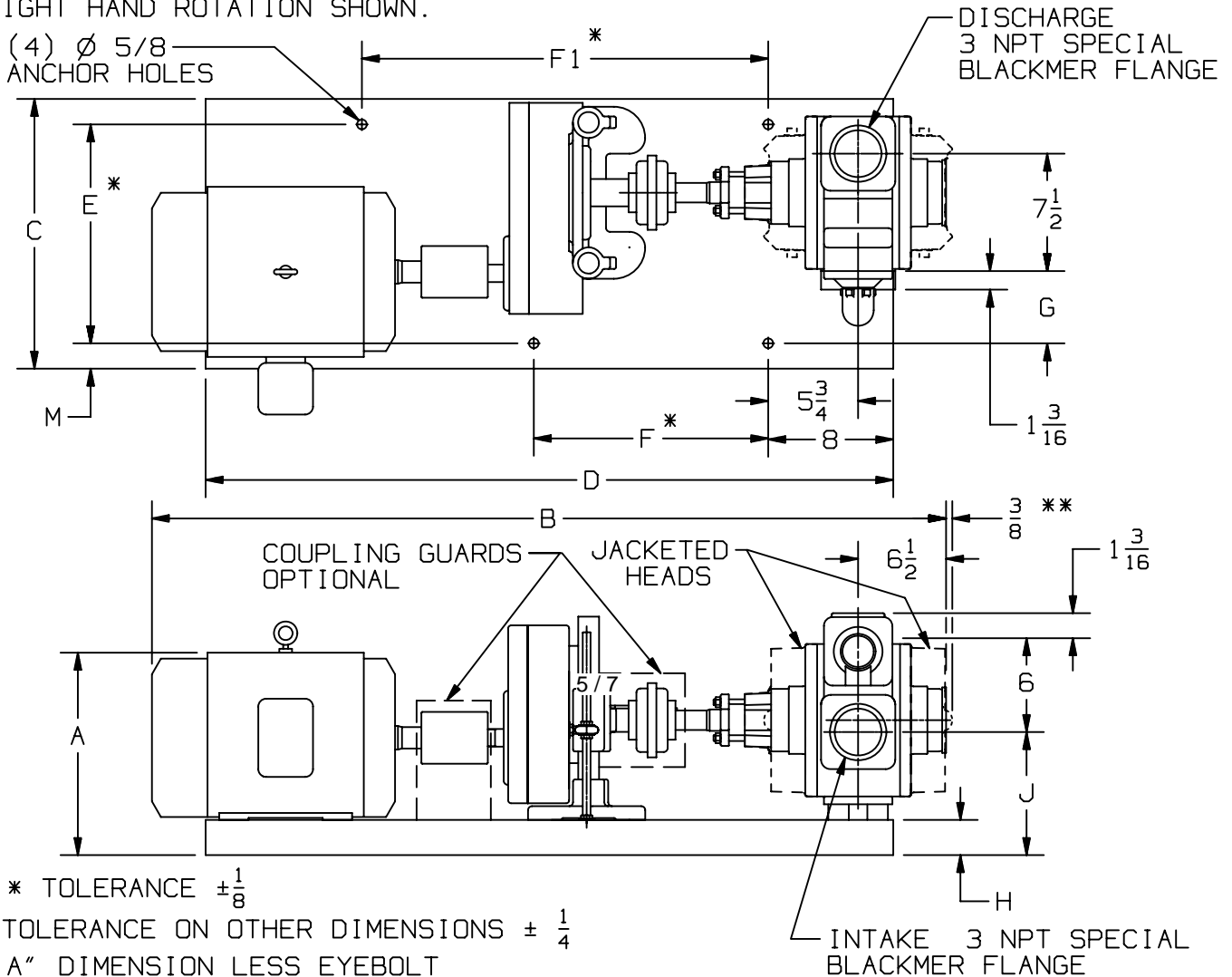

\* TOLERANCE  $\pm \frac{1}{8}$   
 TOLERANCE ON OTHER DIMENSIONS  $\pm \frac{1}{4}$   
 "A" DIMENSION LESS EYEBOLT  
 \*\* FOR JACKETED HEADS

FRAME SIZE	MOTOR		BASE NO.	DIMENSIONS										APPROX. UNIT WT. - POUNDS		
	H.P.	RPM		A	B	C	D	E	F	F1	G	H	J	M	LESS MOTOR	INCL. MOTOR
143T	1	1800	901772	11 1/2	45 3/4	17 1/4	44	14	15	26	4 5/8	2 1/4	7 7/8	1 5/8	400	430
145T	1 1/2	1800	901772	11 1/2	46 3/4	17 1/4	44	14	15	26	4 5/8	2 1/4	7 7/8	1 5/8	400	435
182T	3	1800	901772	12 1/2	48	17 1/4	44	14	15	26	4 5/8	2 1/4	7 7/8	1 5/8	400	490
184T	5	1800	901772	12 1/2	49	17 1/4	44	14	15	26	4 5/8	2 1/4	7 7/8	1 5/8	400	525
213T	7 1/2	1800	901772	13 3/8	51 1/4	17 1/4	44	14	15	26	4 5/8	2 1/4	7 7/8	1 5/8	400	545
215T	10	1800	901772	13 3/8	52 7/8	17 1/4	44	14	15	26	4 5/8	2 1/4	7 7/8	1 5/8	400	560
254T	15	1800	901773	16 1/8	56 1/4	20 3/8	50 1/2	16 3/8	22	33	6 5/8	3	8 3/4	2	485	725
256T	20	1800	901773	16 1/8	58 1/4	20 3/8	50 1/2	16 3/8	22	33	6 5/8	3	8 3/4	2	485	750
284T	25	1800	901773	17 5/8	60 1/4	22	58	16 3/8	22	33	5 13/16	3	8 3/4	2 13/16	485	855
286T	30	1800	901773	17 5/8	61 3/4	22	58	16 3/8	22	33	5 13/16	3	8 3/4	2 13/16	485	870
D160M	15	150	1830	16 1/2	57	20 3/8	50 1/2	16 3/8	22	33	6 5/8	3	8 3/4	2	485	

DIMENSIONS 103-109

Section 103  
 Effective March 2006  
 Replaces November 2001  
 Page 5/5

TYPE

SIZE

UNIT  
 STYLE

NP

3

HRB



www.blackmer.com

LEFT HAND ROTATION SHOWN.

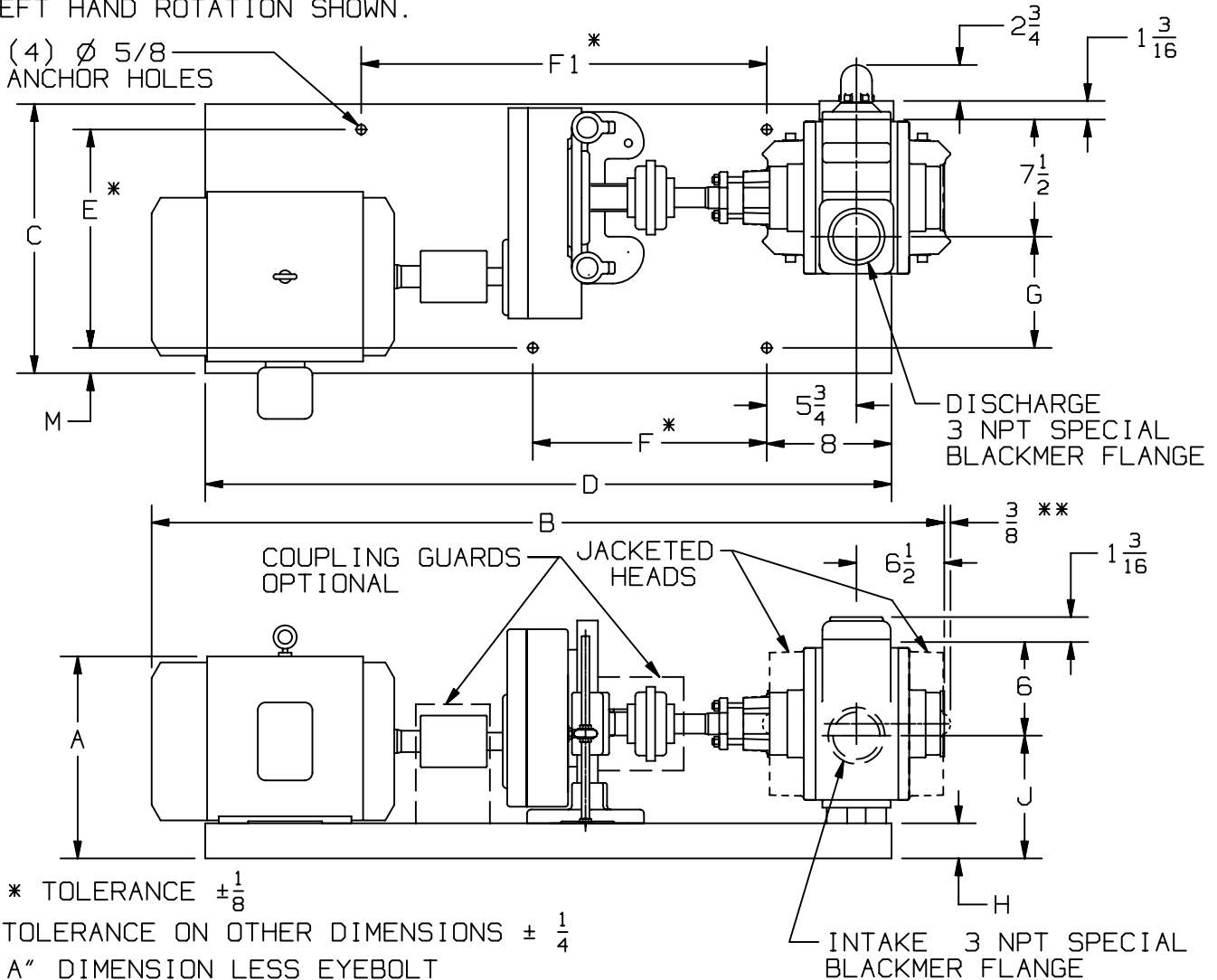

\* TOLERANCE  $\pm \frac{1}{8}$

TOLERANCE ON OTHER DIMENSIONS  $\pm \frac{1}{4}$

"A" DIMENSION LESS EYEBOLT

\*\* FOR JACKETED HEADS

FRAME SIZE	MOTOR		BASE NO.	DIMENSIONS											APPROX. UNIT WT. - POUNDS	
	H. P.	RPM		A	B	C	D	E	F	F1	G	H	J	M	LESS MOTOR	INCL. MOTOR
143T	1	1800	901772	11 1/2	45 3/4	17 1/4	44	14	15	26	7 1/8	2 1/4	7 7/8	1 5/8	400	430
145T	1 1/2 & 2	1800	901772	11 1/2	46 3/4	17 1/4	44	14	15	26	7 1/8	2 1/4	7 7/8	1 5/8	400	435
182T	3	1800	901772	12 1/2	48	17 1/4	44	14	15	26	7 1/8	2 1/4	7 7/8	1 5/8	400	490
184T	5	1800	901772	12 1/2	49	17 1/4	44	14	15	26	7 1/8	2 1/4	7 7/8	1 5/8	400	525
213T	7 1/2	1800	901772	13 3/8	51 1/4	17 1/4	44	14	15	26	7 1/8	2 1/4	7 7/8	1 5/8	400	545
215T	10	1800	901772	13 3/8	52 7/8	17 1/4	44	14	15	26	7 1/8	2 1/4	7 7/8	1 5/8	400	560
254T	15	1800	901773	16 1/8	56 1/4	20 3/8	50 1/2	16 3/8	22	33	9 1/8	3	8 3/4	2	485	725
256T	20	1800	901773	16 1/8	58 1/4	20 3/8	50 1/2	16 3/8	22	33	9 1/8	3	8 3/4	2	485	750
284T	25	1800	901773	17 5/8	60 1/4	22	58	16 3/8	22	33	8 5/16	3	8 3/4	2 13/16	485	855
286T	30	1800	901773	17 5/8	61 3/4	22	58	16 3/8	22	33	8 5/16	3	8 3/4	2 13/16	485	870