



TYPE	SIZE	UNIT STYLE	DIMENSIONS 103-106	
NPH	2	PO	Section	103
			Effective	OCTOBER 2015
			Replaces	NEW
			Page 1 / 3	

RIGHT HAND ROTATION SHOWN. FOR LEFT HAND ROTATION, SHAFT PROJECTION IS OPPOSITE OF VIEW SHOWN.

*TOLERANCE $\pm 1/8"$

TOLERANCE ON OTHER DIMENSIONS $\pm 1/4"$

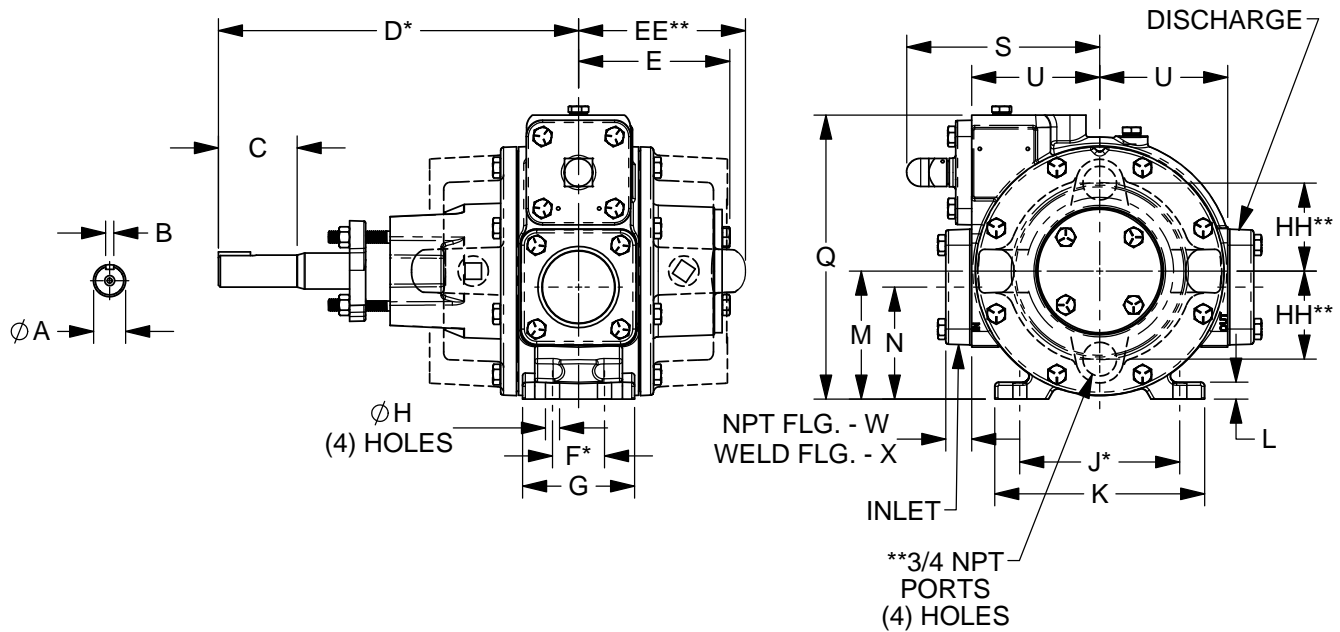

** OPTIONAL STEAM JACKET ONLY

"Q" DIMENSION LESS PUMP EYEBOLT

NOTE: FOR ANSI FLANGE DIMENSIONS, SEE DIMENSIONS SHEET 103-115.

DIMENSIONS											WEIGHTS		
UNITS	A	B	C	D	E	F	G	H	J	K	UNITS	PUMP ONLY	PUMP W/ JACKETED HEADS
IN	1	1/4	2 7/16	11 1/4	4 3/4	1 5/8	3 1/2	7/16	5	6 9/16	LBS	64	74
MM			61,9	285,8	120,7	41,3	88,9	11,1	127	166,7	KG	29	34
	L	M	N	P	Q	R	S	T	U	V		NPT FLANGES	NPT FLANGES
IN	1/2	4	3 1/2	---	8 7/8	---	6	---	4	---	LBS	68	78
MM	12,7	101,6	88,9	---	225,4	---	152,4	---	101,6	---	KG	31	35
	W	X	Y	Z	AA	BB	CC	DD	EE	FF		WELD FLANGES	WELD FLANGES
IN	13/16	1 3/16	---	---	---	---	---	---	5 3/16	---	LBS	69	79
MM	20,6	30,2	---	---	---	---	---	---	131,8	---	KG	31	36
	GG	HH	JJ	KK	LL	MM						ANSI FLANGES	ANSI FLANGES
IN	---	2 3/4	---	---	---	---					LBS	84	94
MM	---	69,9	---	---	---	---					KG	38	43

