



TYPE	SIZE	UNIT STYLE
GNX	2.5	PO

DIMENSIONS 101-206	
Section Effective Replaces Page 1 / 3	101 SEPT 2017 MARCH 2017

RIGHT HAND ROTATION. FOR LEFT HAND ROTATION, SHAFT PROJECTION IS OPPOSITE THAT SHOWN.

*TOLERANCE $\pm 1/8$ "

TOLERANCE ON OTHER DIMENSIONS $\pm 1/4$ "

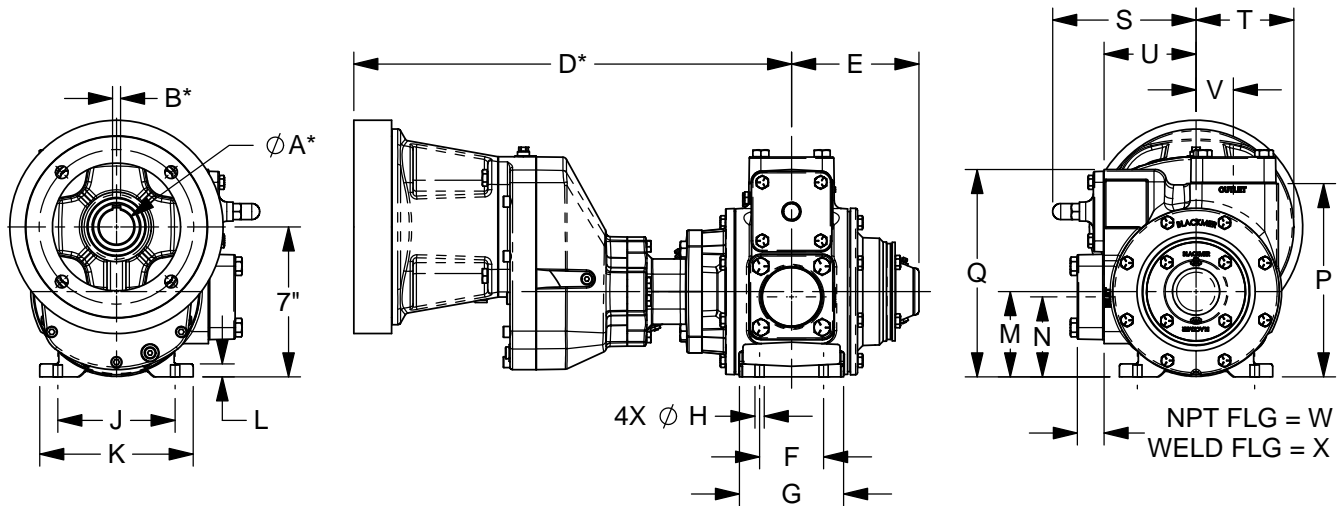

MOTOR SIZE	ϕA^*	B*	D*
NEMA 180TC	1 1/8	1/4	18
NEMA 210TC	1 3/8	5/16	18 3/4
NEMA 250TC	1 5/8	3/8	20 1/2
IEC 100/112 B5	28mm	8mm	16 13/16

DIMENSIONS											WEIGHTS	
UNITS	A	B	C	D	E	F	G	H	J	K	UNITS	PUMP ONLY
IN	---	---	---	---	6	3	4 7/8	7/16	5 1/2	7	LBS	96
MM	---	---	---	---	152,4	76,2	123,8	11,1	139,7	177,8	KG	44
	L	M	N	P	Q	R	S	T	U	V		W/ NPT FLANGES
IN	7/16	4	3 3/4	9 1/16	9 5/8	---	6 13/16	4 9/16	4 5/16	1 3/4	LBS	102
MM	11,1	101,6	95,3	230,2	244,5	---	173	115,9	109,5	44,4	KG	46
	W	X	Y	Z	AA	BB	CC	DD	EE	FF		W/ WELD FLANGES
IN	1 3/16	1 1/4	---	---	---	---	---	---	---	---	LBS	101
MM	30,2	31,8	---	---	---	---	---	---	---	---	KG	46
	GG	HH	JJ	KK	LL	MM						W/ ANSI FLANGES
IN	---	---	---	---	---	---					LBS	126
MM	---	---	---	---	---	---					KG	57

