



TYPE	SIZE	UNIT STYLE	DIMENSIONS 101-205	
			Section Effective Replaces Page 1 / 3	101 SEPT 2017 MARCH 2017
GNX	2	PO		

RIGHT HAND ROTATION. FOR LEFT HAND ROTATION, SHAFT PROJECTION IS OPPOSITE THAT SHOWN.

*TOLERANCE $\pm 1/8"$

TOLERANCE ON OTHER DIMENSIONS $\pm 1/4"$

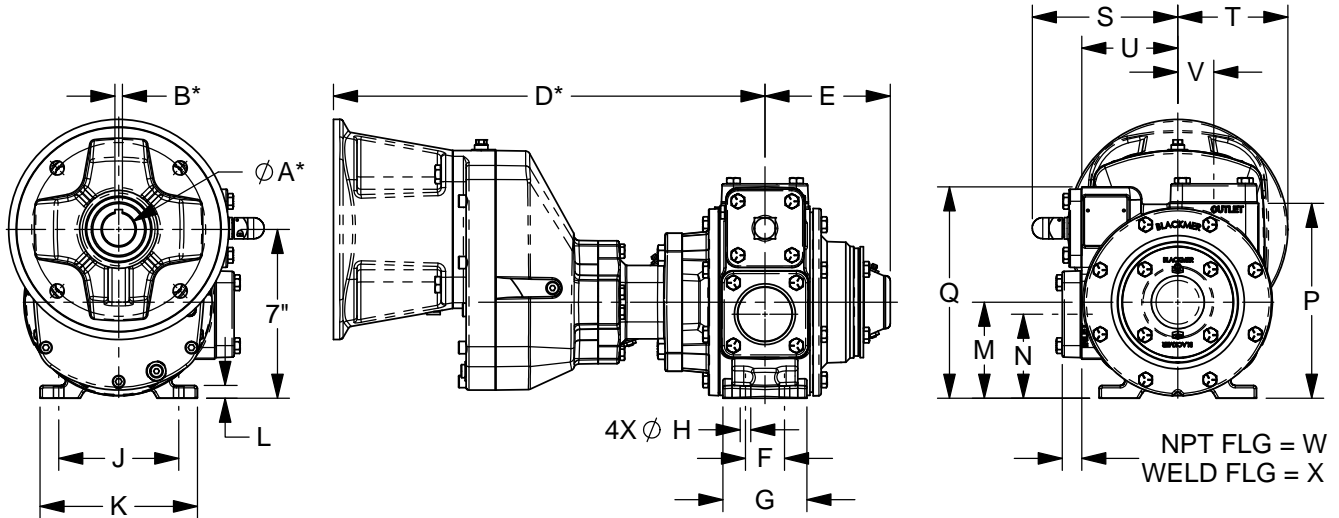

MOTOR SIZE	ϕA^*	B*	D*
NEMA 140TC	7/8	3/16	16 15/16
NEMA 180TC	1 1/8	1/4	17 1/4
NEMA 210TC	1 3/8	5/16	18
IEC 100/112 B5	28mm	8mm	21 5/16

DIMENSIONS											WEIGHTS	
UNITS	A	B	C	D	E	F	G	H	J	K	UNITS	PUMP ONLY
IN	---	---	---	---	5 1/4	1 5/8	3 1/2	7/16	5	6 1/2	LBS	76
MM	---	---	---	---	133,3	41,3	88,9	11,1	127	165,1	KG	34
	L	M	N	P	Q	R	S	T	U	V		W/ NPT FLANGES
IN	1/2	4	3 1/2	8 1/8	8 13/16	---	5 7/8	4 9/16	4	1 1/2	LBS	80
MM	12,7	101,6	88,9	206,4	220,6	---	149,2	115,9	101,6	38,1	KG	36
	W	X	Y	Z	AA	BB	CC	DD	EE	FF		W/ WELD FLANGES
IN	3/4	1 3/16	---	---	---	---	---	---	---	---	LBS	81
MM	19,1	30,2	---	---	---	---	---	---	---	---	KG	37
	GG	HH	JJ	KK	LL	MM						W/ ANSI FLANGES
IN	---	---	---	---	---	---					LBS	95
MM	---	---	---	---	---	---					KG	43

