

TYPE	SIZE	UNIT STYLE
X	2B	PO

DIMENSIONS 101-109	
Section	101
Effective	February 2003
Replaces	October 1995
Page 1/7	

RIGHT HAND ROTATION. FOR LEFT HAND ROTATION, SHAFT PROJECTION IS OPPOSITE THAT SHOWN.

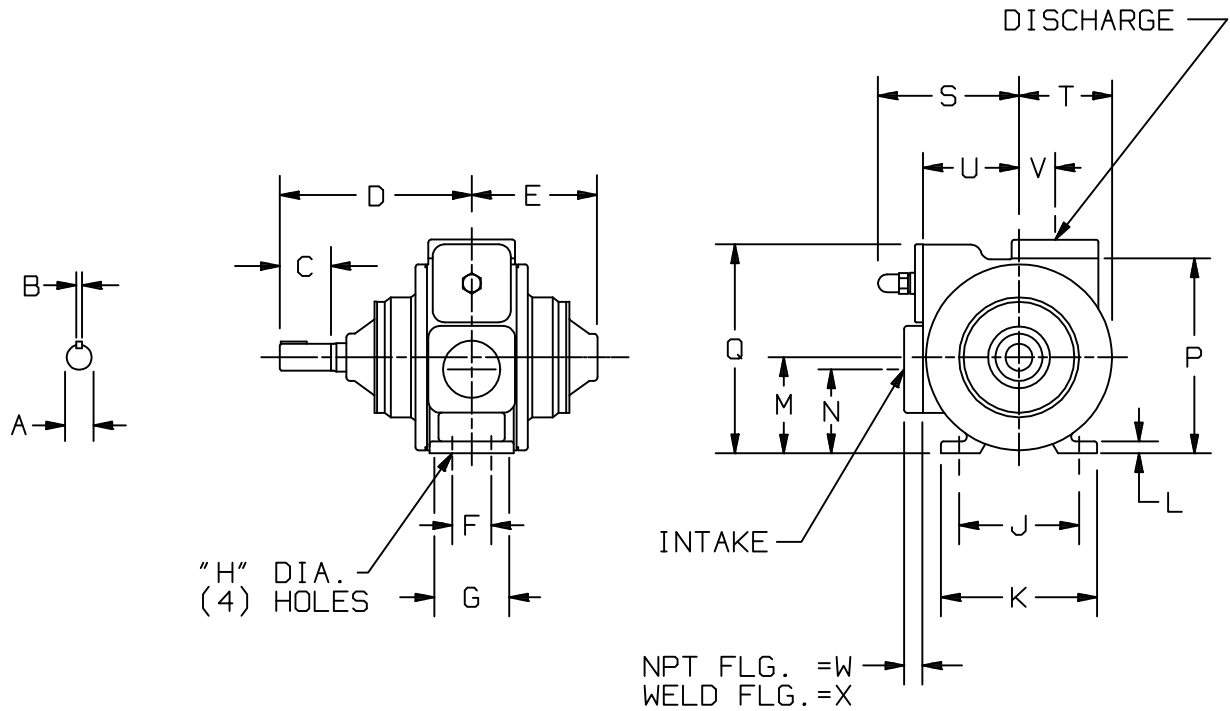

MOTOR			UNITS	DIMENSIONS									
FRAME SIZE				A	B	C	D	E	F	G	H	J	K
			IN	1 1/8	1/4	2 1/4	8	5 1/4	1 5/8	3 1/2	7/16	5	6 1/2
			MM	28,6	6,4	57,2	203,2	133,4	41,3	88,9	11,1	127	165,1
				L	M	N	P	Q	R	S	T	U	V
			IN	1/2	4	3 1/2	8 1/8	8 11/16	—	5 7/8	3 7/8	4	1 1/2
			MM	12,7	101,6	88,9	206,4	220,6	—	149,2	98,4	101,6	38,1
				W	X	Y	Z	AA	BB	CC	DD	EE	FF
			IN	3/4	1 3/16	—	—	—	—	—	—	—	—
			MM	19,1	30,2	—	—	—	—	—	—	—	—
				GG	HH					PUMP WEIGHT	WITH STD. FLANGES		
			IN	—	—					LBS	70		
			MM	—	—					KG	32		

TYPE	SIZE	UNIT STYLE
X	2B	HROF

DIMENSIONS 101-109	
Section	101
Effective	February 2003
Replaces	October 1995
Page 2/7	

RIGHT HAND ROTATION

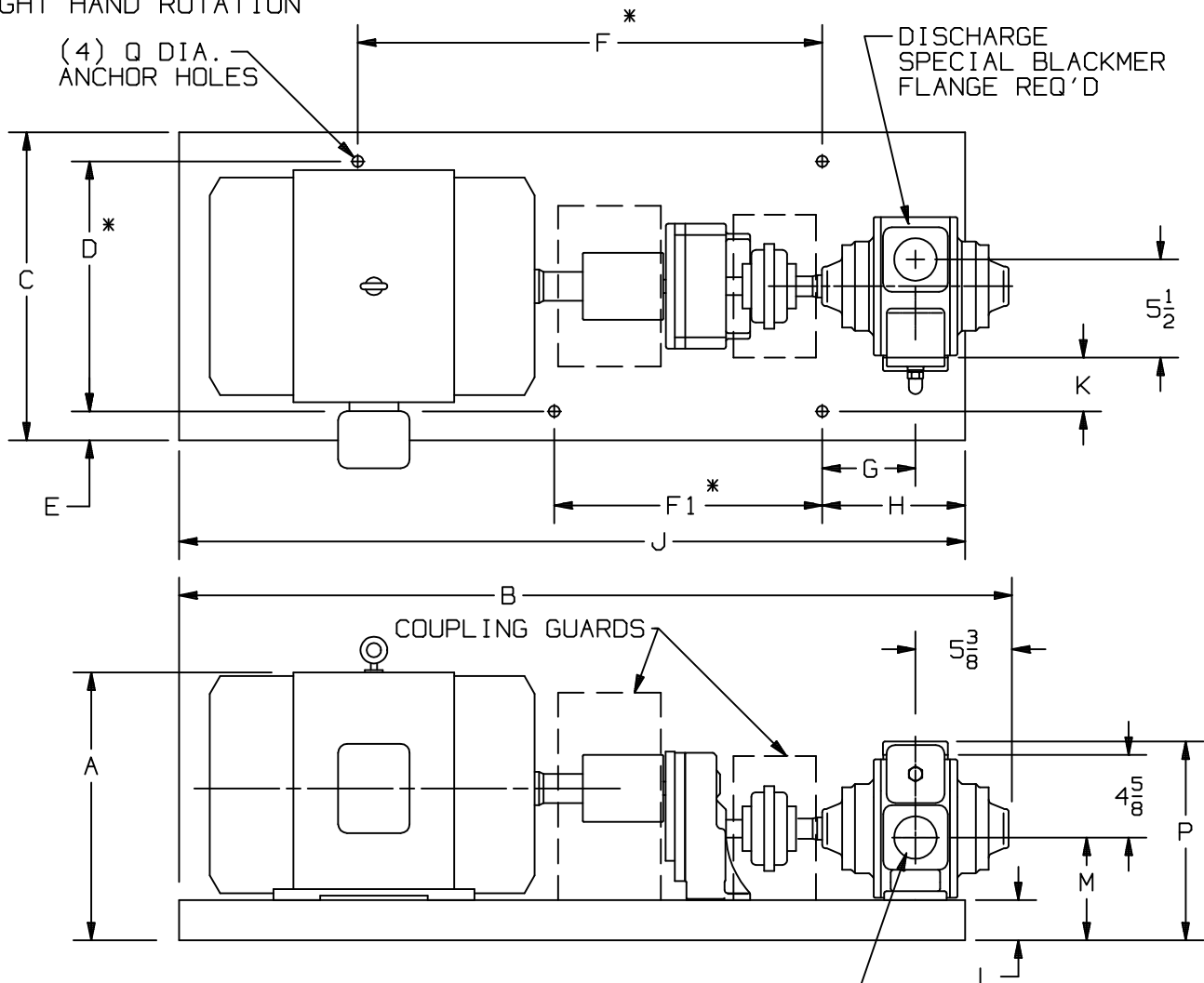

UNIT DIMENSION LESS FLANGES

* TOLERANCE $\pm \frac{1}{8}$

TOLERANCE ON OTHER DIMENSIONS $\pm \frac{1}{4}$

"A" DIMENSION LESS EYEBOLT

FLG. HGT: 2" NPT - 3/4
2" WELD - 1 3/16

MOTOR			DIMENSIONS														
FRAME SIZE		BASE NO.	A	B	C	D	E	F	F1	G	H	J	K	L	M	P	Q
143T		901790	12 1/4	36 1/2	14 3/4	10	2 3/8	12	12	3 1/4	6	33	1	1 3/4	5 1/4	10 7/8	7/16
145T		901790	12 1/4	37 3/8	14 3/4	10	2 3/8	12	12	3 1/4	6	33	1	1 3/4	5 1/4	10 7/8	7/16
182T		901790	13 3/8	38 3/8	14 3/4	10	2 3/8	12	12	3 1/4	6	33	1	1 3/4	5 1/4	10 7/8	7/16
184T		901790	13 3/8	39 3/4	14 3/4	10	2 3/8	12	12	3 1/4	6	33	1	1 3/4	5 1/4	10 7/8	7/16
213T		901791	14 5/8	47 3/8	17 1/4	14	1 5/8	26	15	5 1/4	8	44	3	2 1/4	5 3/4	11 3/8	5/8
215T		901791	14 5/8	47 3/8	17 1/4	14	1 5/8	26	15	5 1/4	8	44	3	2 1/4	5 3/4	11 3/8	5/8
254T		901791	15 7/8	47 3/8	17 1/4	14	1 5/8	26	15	5 1/4	8	44	3	2 1/4	5 3/4	11 3/8	5/8
256T		901791	15 7/8	48 5/8	17 1/4	14	1 5/8	26	15	5 1/4	8	44	3	2 1/4	5 3/4	11 3/8	5/8

DIMENSIONS 101-109

Section 101
 Effective February 2003
 Replaces October 1995
 Page 3/7

TYPE

SIZE

UNIT
STYLE

X

2B

HROF

Blackmer

www.blackmer.com

LEFT HAND ROTATION

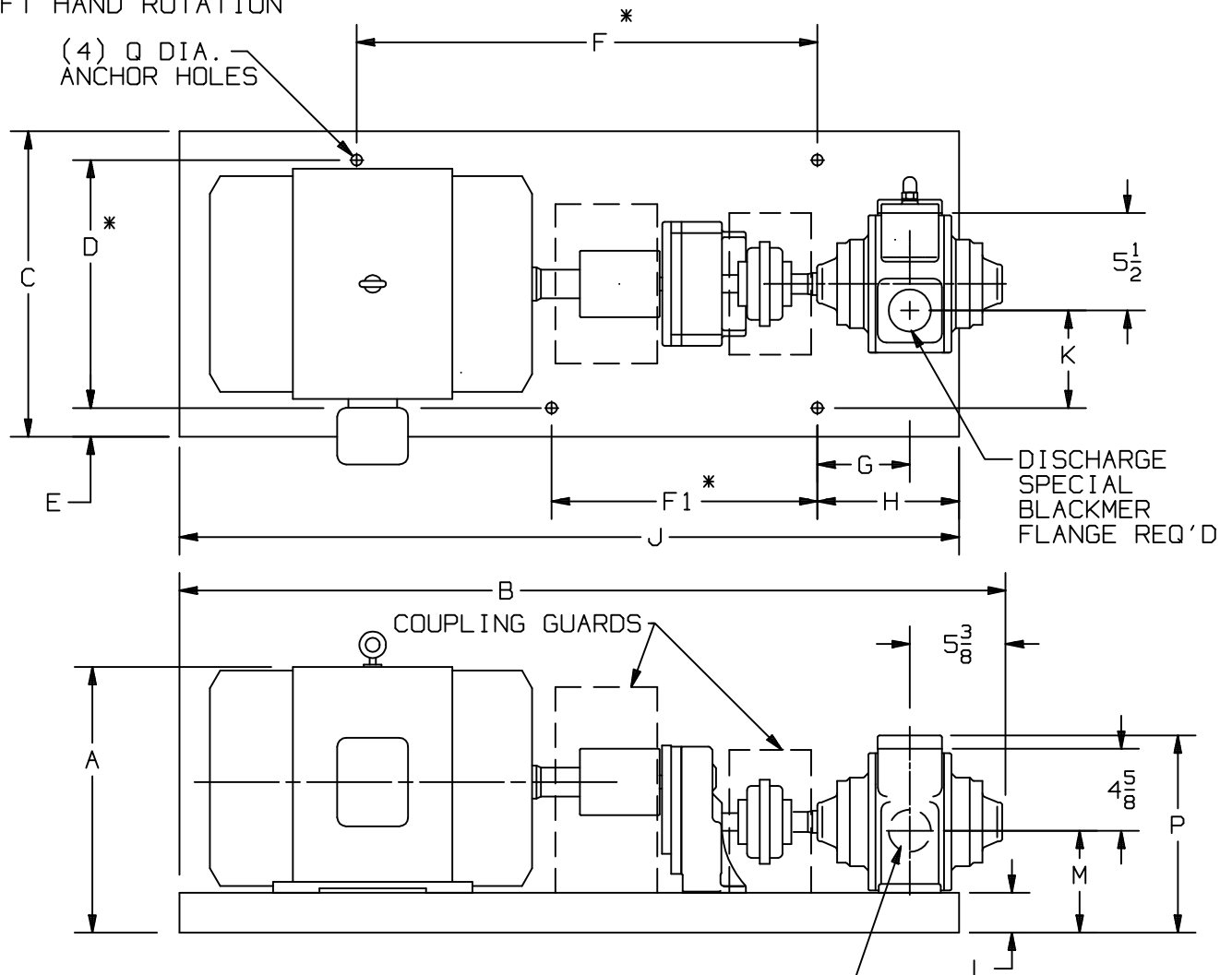

UNIT DIMENSION LESS FLANGES

* TOLERANCE $\pm \frac{1}{8}$

TOLERANCE ON OTHER DIMENSIONS $\pm \frac{1}{4}$

"A" DIMENSION LESS EYEBOLT

FLG. HGT: 2" NPT - 3/4
 2" WELD - 1 3/16

MOTOR			DIMENSIONS														
FRAME SIZE		BASE NO.	A	B	C	D	E	F	F1	G	H	J	K	L	M	P	Q
143T		901790	12 1/4	36 1/2	14 3/4	10	2 3/8	12	12	3 1/4	6	33	3 1/2	1 3/4	5 1/4	10 7/8	7/16
145T		901790	12 1/4	37 3/8	14 3/4	10	2 3/8	12	12	3 1/4	6	33	3 1/2	1 3/4	5 1/4	10 7/8	7/16
182T		901790	13 3/8	38 3/8	14 3/4	10	2 3/8	12	12	3 1/4	6	33	3 1/2	1 3/4	5 1/4	10 7/8	7/16
184T		901790	13 3/8	39 3/4	14 3/4	10	2 3/8	12	12	3 1/4	6	33	3 1/2	1 3/4	5 1/4	10 7/8	7/16
213T		901791	14 5/8	47 3/8	17 1/4	14	1 5/8	26	15	5 1/4	8	44	5 1/2	2 1/4	5 3/4	11 3/8	5/8
215T		901791	14 5/8	47 3/8	17 1/4	14	1 5/8	26	15	5 1/4	8	44	5 1/2	2 1/4	5 3/4	11 3/8	5/8
254T		901791	15 7/8	47 3/8	17 1/4	14	1 5/8	26	15	5 1/4	8	44	5 1/2	2 1/4	5 3/4	11 3/8	5/8
256T		901791	15 7/8	48 5/8	17 1/4	14	1 5/8	26	15	5 1/4	8	44	5 1/2	2 1/4	5 3/4	11 3/8	5/8

TYPE	SIZE	UNIT STYLE
X	2B	HRA

DIMENSIONS 101-109	
Section	101
Effective	February 2003
Replaces	April 2000
Page	4/7

RIGHT HAND ROTATION

(4) $\varnothing \frac{5}{8}$ ANCHOR HOLES

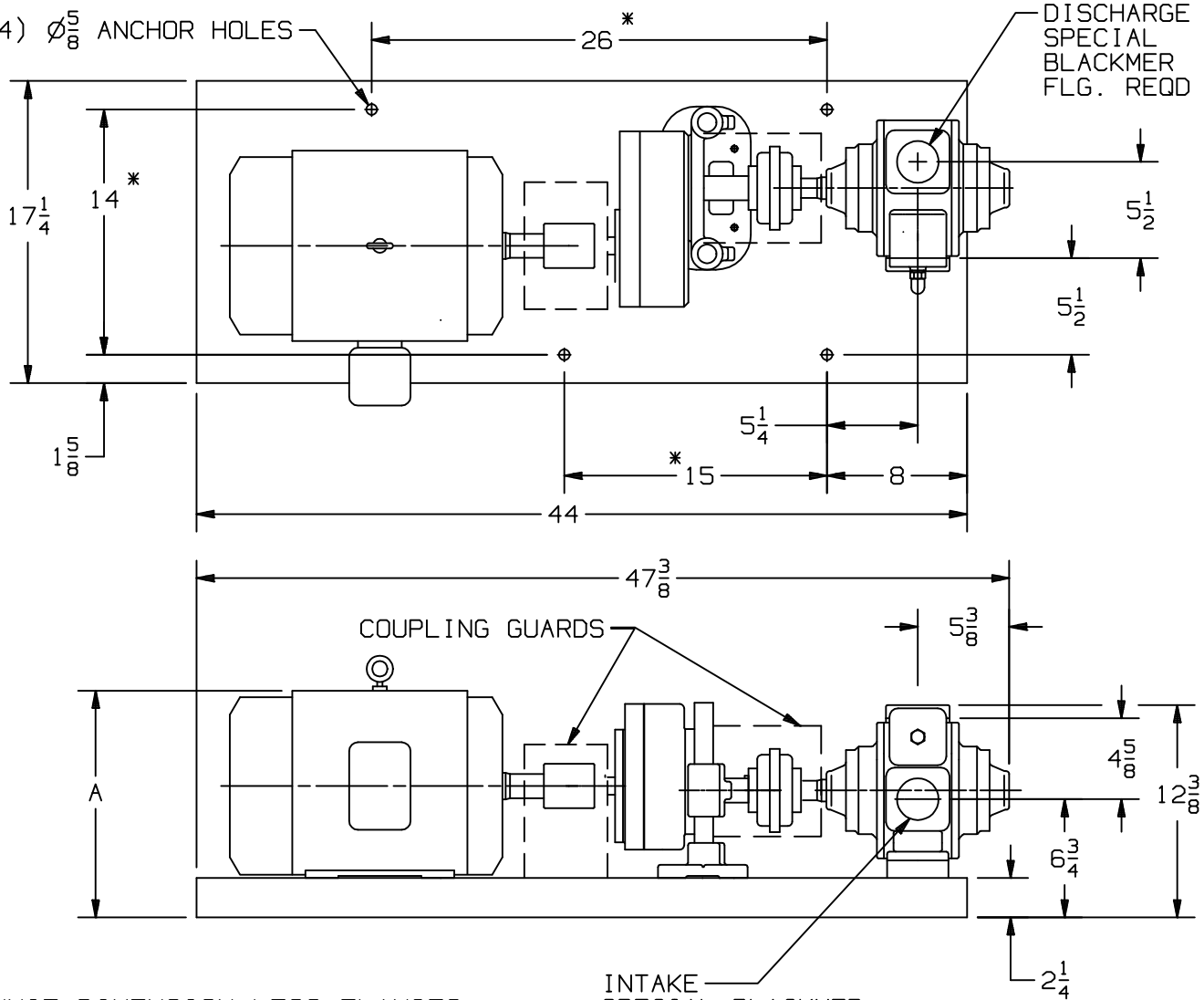

UNIT DIMENSION LESS FLANGES

* TOLERANCE $\pm \frac{1}{8}$

TOLERANCE ON OTHER DIMENSIONS $\pm \frac{1}{4}$

"A" DIMENSION LESS EYEBOLT

FLG HGT: 2" NPT - 3/4
2" WELD - 1 3/16

MOTOR			BASE NO.	DIMENSIONS	
FRAME SIZE		UNITS		A	
182T		901776	IN	11 7/8	
			MM	301,6	
184T		901776	IN	11 7/8	
			MM	301,6	
213T		901776	IN	13 3/8	
			MM	339,7	
215T		901776	IN	13 3/8	
			MM	339,7	

DIMENSIONS 101-109

Section 101
 Effective February 2003
 Replaces April 2000
 Page 5/7

TYPE	SIZE	UNIT STYLE
X	2B	HRA



LEFT HAND ROTATION

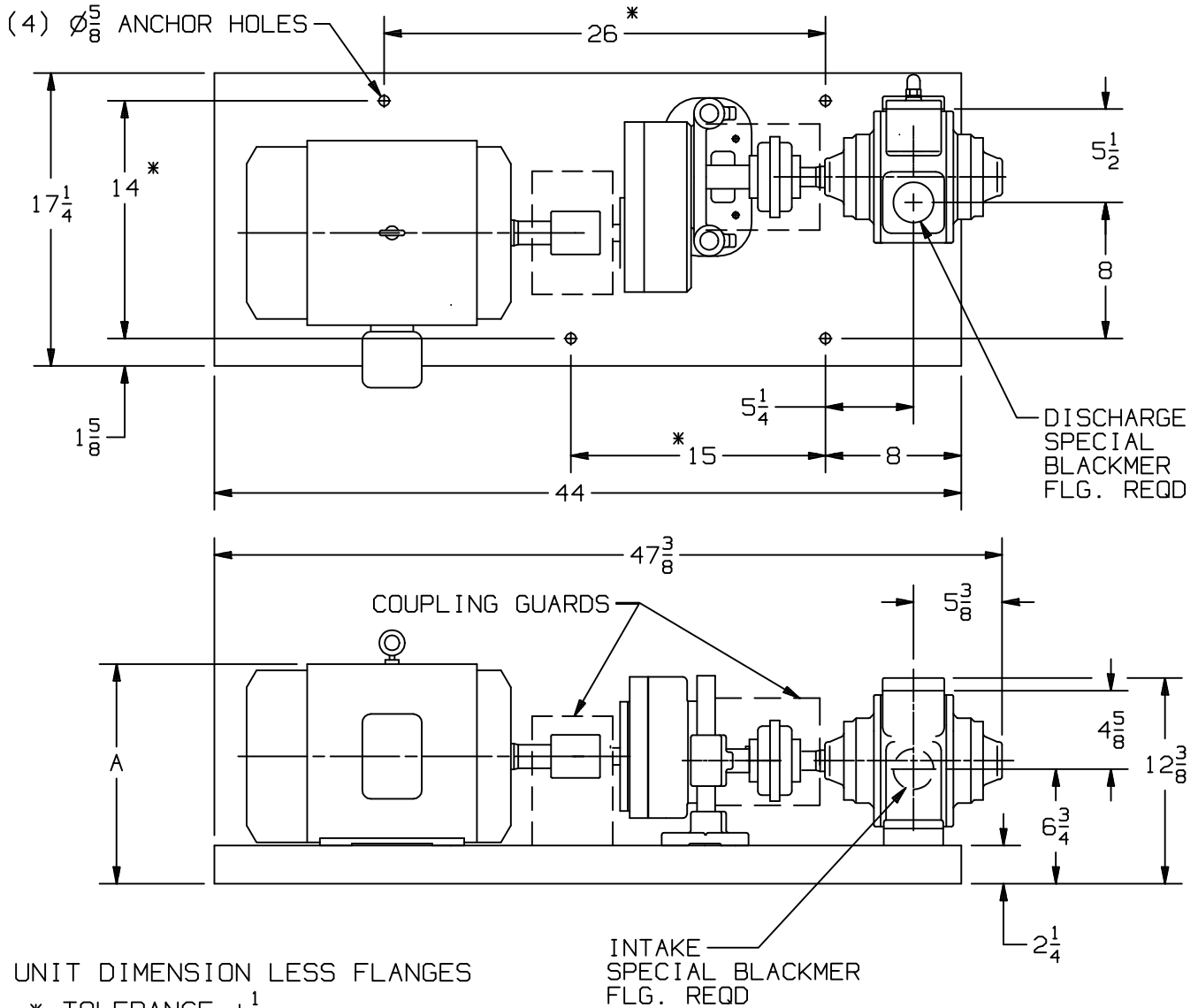

UNIT DIMENSION LESS FLANGES

* TOLERANCE $\pm \frac{1}{8}$

TOLERANCE ON OTHER DIMENSIONS $\pm \frac{1}{4}$

"A" DIMENSION LESS EYEBOLT

FLG HGT: 2" NPT - 3/4
 2" WELD - 1 3/16

MOTOR			BASE NO.	DIMENSIONS	
FRAME SIZE		UNITS		A	
182T		901776	IN	11 $\frac{7}{8}$	
			MM	301,6	
184T		901776	IN	11 $\frac{7}{8}$	
			MM	301,6	
213T		901776	IN	13 $\frac{3}{8}$	
			MM	339,7	
215T		901776	IN	13 $\frac{3}{8}$	
			MM	339,7	

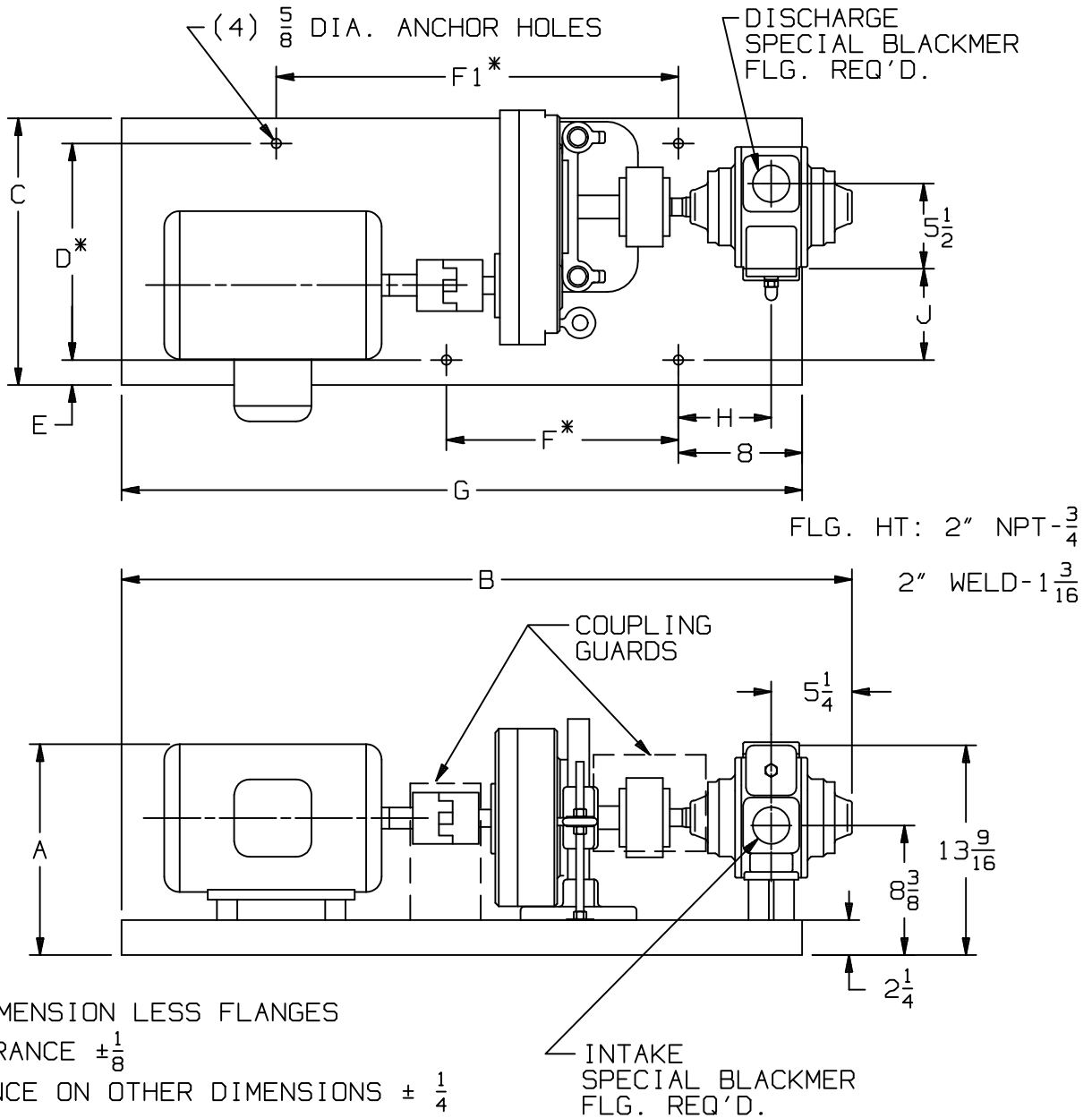

UNIT DIMENSION LESS FLANGES

* TOLERANCE $\pm \frac{1}{8}$

TOLERANCE ON OTHER DIMENSIONS $\pm \frac{1}{4}$

"A" DIMENSION LESS EYEBOLT

MOTOR			BASE NO.	DIMENSIONS											
FRAME SIZE				UNITS	A	B	C	D	E	F	F1	G	H	J	L
182T		901777	IN	12 $\frac{7}{8}$	48 $\frac{1}{4}$	17 $\frac{1}{4}$	14	1 $\frac{5}{8}$	15	26	44	6	5 $\frac{7}{8}$	—	—
			MM	327,2	1225,6	438,2	327,2	41,3	381	660,4	1117,6	152,4	149,2	—	—
186T		901777	IN	12 $\frac{7}{8}$	48 $\frac{1}{4}$	17 $\frac{1}{4}$	14	1 $\frac{5}{8}$	15	26	44	6	5 $\frac{7}{8}$	—	—
			MM	327,2	1225,6	438,2	327,2	41,3	381	660,4	1117,6	152,4	149,2	—	—
213T		901777	IN	13 $\frac{5}{8}$	48 $\frac{1}{4}$	17 $\frac{1}{4}$	14	1 $\frac{5}{8}$	15	26	44	6	5 $\frac{7}{8}$	—	—
			MM	346,1	1225,6	438,2	327,2	41,3	381	660,4	1117,6	152,4	149,2	—	—
215T		901777	IN	13 $\frac{5}{8}$	48 $\frac{1}{4}$	17 $\frac{1}{4}$	14	1 $\frac{5}{8}$	15	26	44	6	5 $\frac{7}{8}$	—	—
			MM	346,1	1225,6	438,2	327,2	41,3	381	660,4	1117,6	152,4	149,2	—	—

DIMENSIONS 101-109

Section 101
 Effective February 2003
 Replaces October 1995
 Page 7/7

TYPE
 X
 LEFT HAND
 ROTATION

SIZE
 2B

UNIT
 STYLE
 HRB

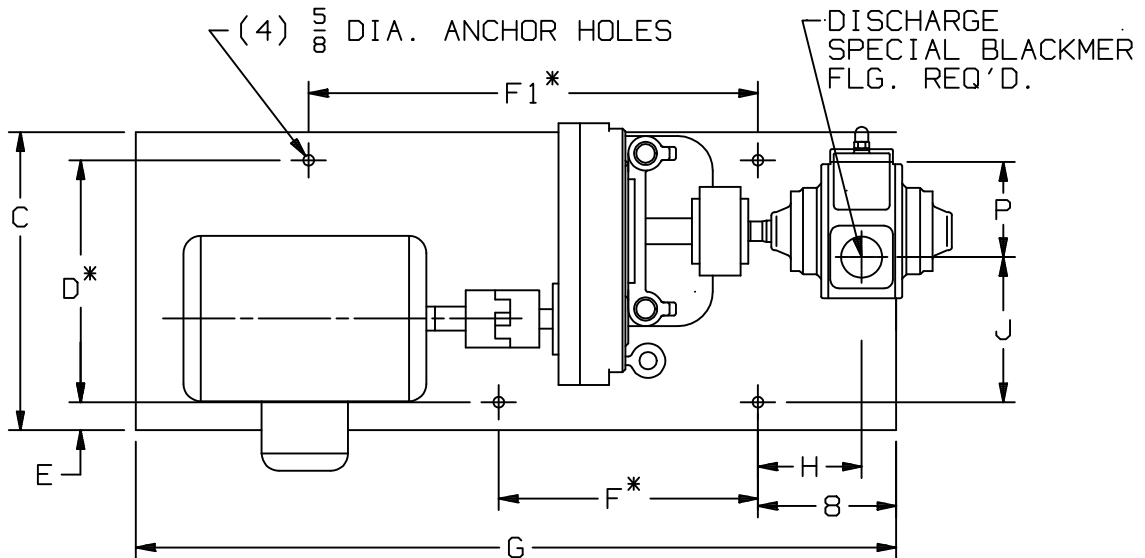

FLG. HT: 2" NPT- $\frac{3}{4}$
 2" WELD-1 $\frac{3}{16}$

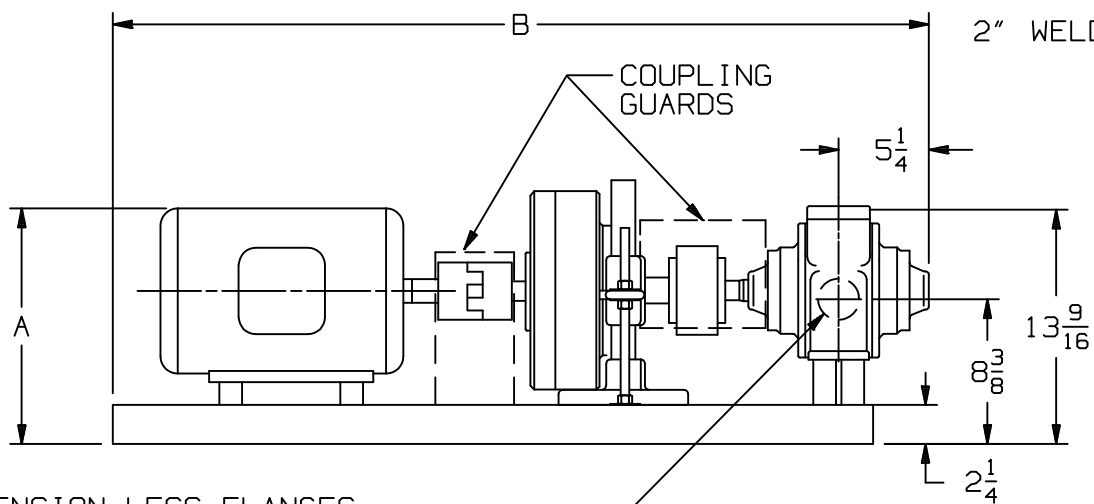

UNIT DIMENSION LESS FLANGES

* TOLERANCE $\pm \frac{1}{8}$

TOLERANCE ON OTHER DIMENSIONS $\pm \frac{1}{4}$

"A" DIMENSION LESS EYEBOLT

MOTOR			BASE NO.	DIMENSIONS												
FRAME SIZE				UNITS	A	B	C	D	E	F	F1	G	H	J	L	M
182T			901777	IN	12 $\frac{7}{8}$	48 $\frac{1}{4}$	17 $\frac{1}{4}$	14	1 $\frac{5}{8}$	15	26	44	6	8 $\frac{3}{8}$	—	—
				MM	327,2	1225,6	438,2	327,2	41,3	381	660,4	1117,6	152,4	212,7	—	—
186T			901777	IN	12 $\frac{7}{8}$	48 $\frac{1}{4}$	17 $\frac{1}{4}$	14	1 $\frac{5}{8}$	15	26	44	6	8 $\frac{3}{8}$	—	—
				MM	327,2	1225,6	438,2	327,2	41,3	381	660,4	1117,6	152,4	212,7	—	—
213T			901777	IN	13 $\frac{5}{8}$	48 $\frac{1}{4}$	17 $\frac{1}{4}$	14	1 $\frac{5}{8}$	15	26	44	6	8 $\frac{3}{8}$	—	—
				MM	346,1	1225,6	438,2	327,2	41,3	381	660,4	1117,6	152,4	212,7	—	—
215T			901777	IN	13 $\frac{5}{8}$	48 $\frac{1}{4}$	17 $\frac{1}{4}$	14	1 $\frac{5}{8}$	15	26	44	6	8 $\frac{3}{8}$	—	—
				MM	346,1	1225,6	438,2	327,2	41,3	381	660,4	1117,6	152,4	212,7	—	—