



TYPE	SIZE	UNIT STYLE
GX	3E	PO

DIMENSIONS 101-107

Section	101
Effective	February 2003
Replaces	October 1995
Page	1/3

RIGHT HAND ROTATION. FOR LEFT HAND ROTATION, SHAFT PROJECTION IS OPPOSITE THAT SHOWN.

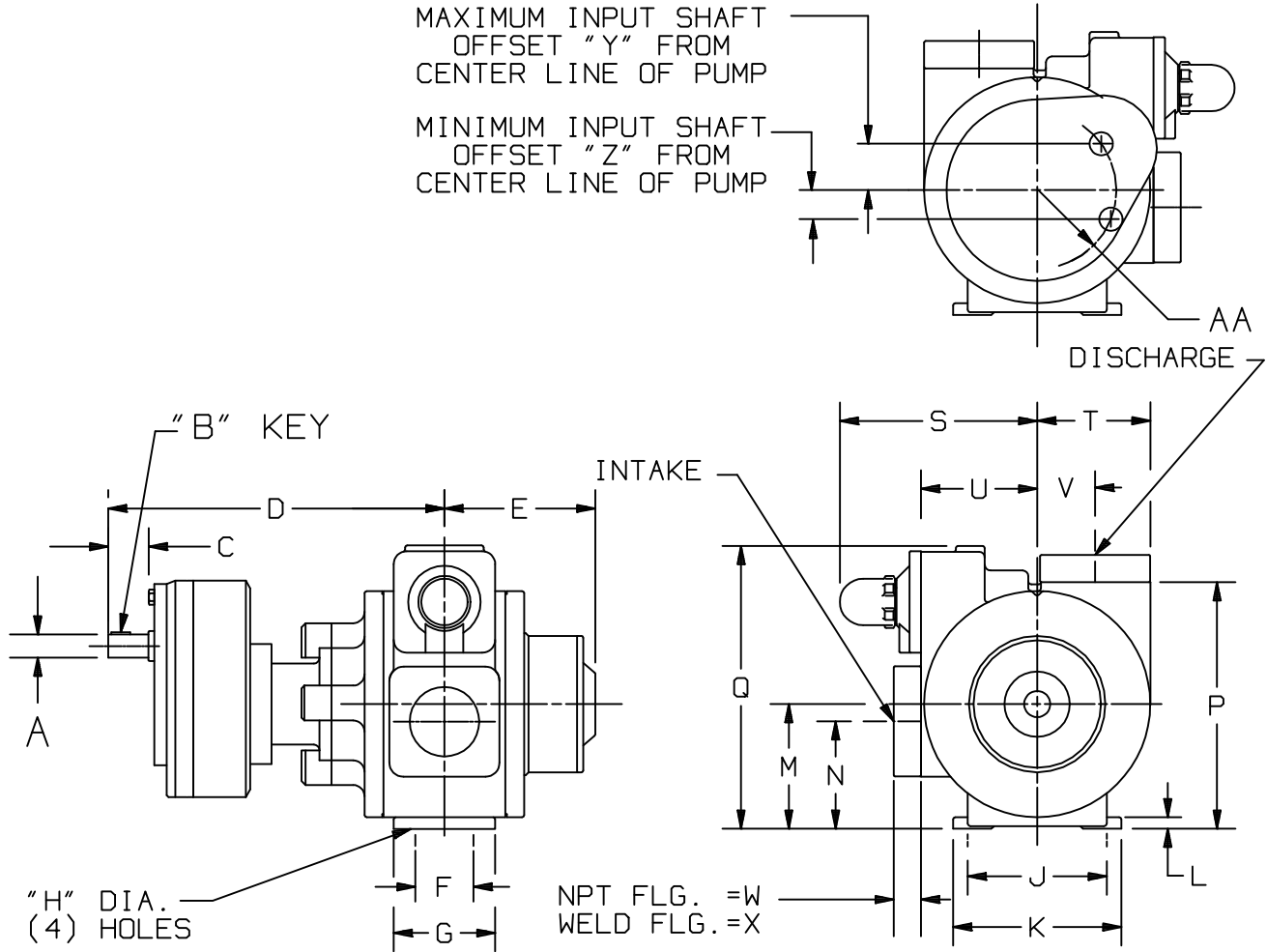

MOTOR			UNITS	DIMENSIONS									
FRAME SIZE				A	B	C	D	E	F	G	H	J	K
			IN	1	1/4	1 3/4	14 1/2	6 3/8	2 1/2	4 3/8	5/8	6	7 1/4
			MM	25,4	6,4	44,5	368,3	161,9	63,5	111,1	15,9	152,4	184,2
				L	M	N	P	Q	R	S	T	U	V
			IN	1/2	5 3/8	4 5/8	10 5/8	12 1/4	—	8 9/16	4 7/8	5	2 1/2
			MM	12,7	136,6	117,5	269,9	311,2	—	217,5	123,8	127	63,5
				W	X	Y	Z	AA	BB	CC	DD	EE	FF
			IN	1 1/8	1 3/16	2	1 1/4	3 3/8	—	—	—	—	—
			MM	28,6	30,2	50,8	31,8	9,5	—	—	—	—	—
				GG	HH					PUMP WEIGHT	WITH STD. FLANGES		
			IN	—	—					LBS	230		
			MM	—	—					KG	104		

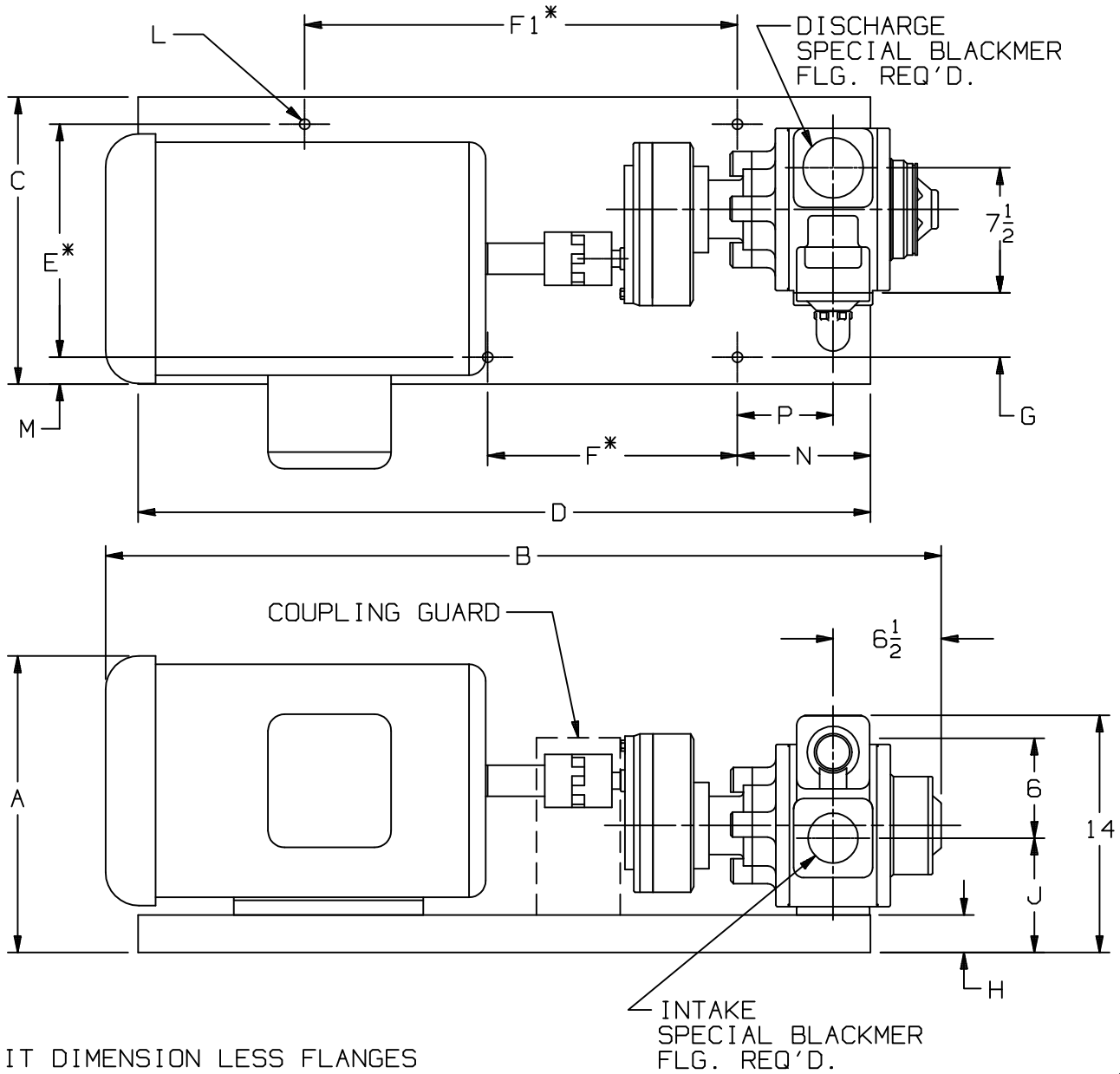

UNIT DIMENSION LESS FLANGES

* TOLERANCE $\pm \frac{1}{8}$

TOLERANCE ON OTHER DIMENSIONS $\pm \frac{1}{4}$

"A" DIMENSION LESS EYEBOLT

FLG. HT: 3" NPT-1 $\frac{1}{8}$

3" WELD-1 $\frac{3}{16}$

FRAME SIZE	MOTOR	UNITS	DIMENSIONS													
			A	B	C	D	E	F	F1	G	H	J	L	M	N	P
182T		901770	10 $\frac{7}{8}$	37 $\frac{3}{8}$	14 $\frac{3}{4}$	33	11 $\frac{1}{4}$	12	12	2 $\frac{3}{8}$	1 $\frac{3}{4}$	6 $\frac{3}{8}$	$\frac{7}{16}$	1 $\frac{3}{4}$	6	3 $\frac{1}{8}$
184T		901770	10 $\frac{7}{8}$	38 $\frac{3}{8}$	14 $\frac{3}{4}$	33	11 $\frac{1}{4}$	12	12	2 $\frac{3}{8}$	1 $\frac{3}{4}$	6 $\frac{3}{8}$	$\frac{7}{16}$	1 $\frac{3}{4}$	6	3 $\frac{1}{8}$
213T		901770	12 $\frac{3}{8}$	40 $\frac{7}{8}$	14 $\frac{3}{4}$	33	11 $\frac{1}{4}$	12	12	2 $\frac{3}{8}$	1 $\frac{3}{4}$	6 $\frac{3}{8}$	$\frac{7}{16}$	1 $\frac{3}{4}$	6	3 $\frac{1}{8}$
215T		901770	12 $\frac{3}{8}$	41 $\frac{5}{8}$	14 $\frac{3}{4}$	33	11 $\frac{1}{4}$	12	12	2 $\frac{3}{8}$	1 $\frac{3}{4}$	6 $\frac{3}{8}$	$\frac{7}{16}$	1 $\frac{3}{4}$	6	3 $\frac{1}{8}$
254T		901676	14 $\frac{3}{4}$	45 $\frac{1}{8}$	17 $\frac{1}{4}$	44	14	15	26	4 $\frac{7}{16}$	2 $\frac{1}{4}$	6 $\frac{7}{8}$	$\frac{5}{8}$	1 $\frac{5}{8}$	8	5 $\frac{1}{2}$
256T		901676	14 $\frac{3}{4}$	46 $\frac{7}{8}$	17 $\frac{1}{4}$	44	14	15	26	4 $\frac{7}{16}$	2 $\frac{1}{4}$	6 $\frac{7}{8}$	$\frac{5}{8}$	1 $\frac{5}{8}$	8	5 $\frac{1}{2}$

DIMENSIONS 101-107

Section 101
 Effective February 2003
 Replaces June 2002
 Page 3/3

TYPE
 GX
 LEFT HAND
 ROTATION

SIZE
 3E

UNIT
 STYLE
 GX

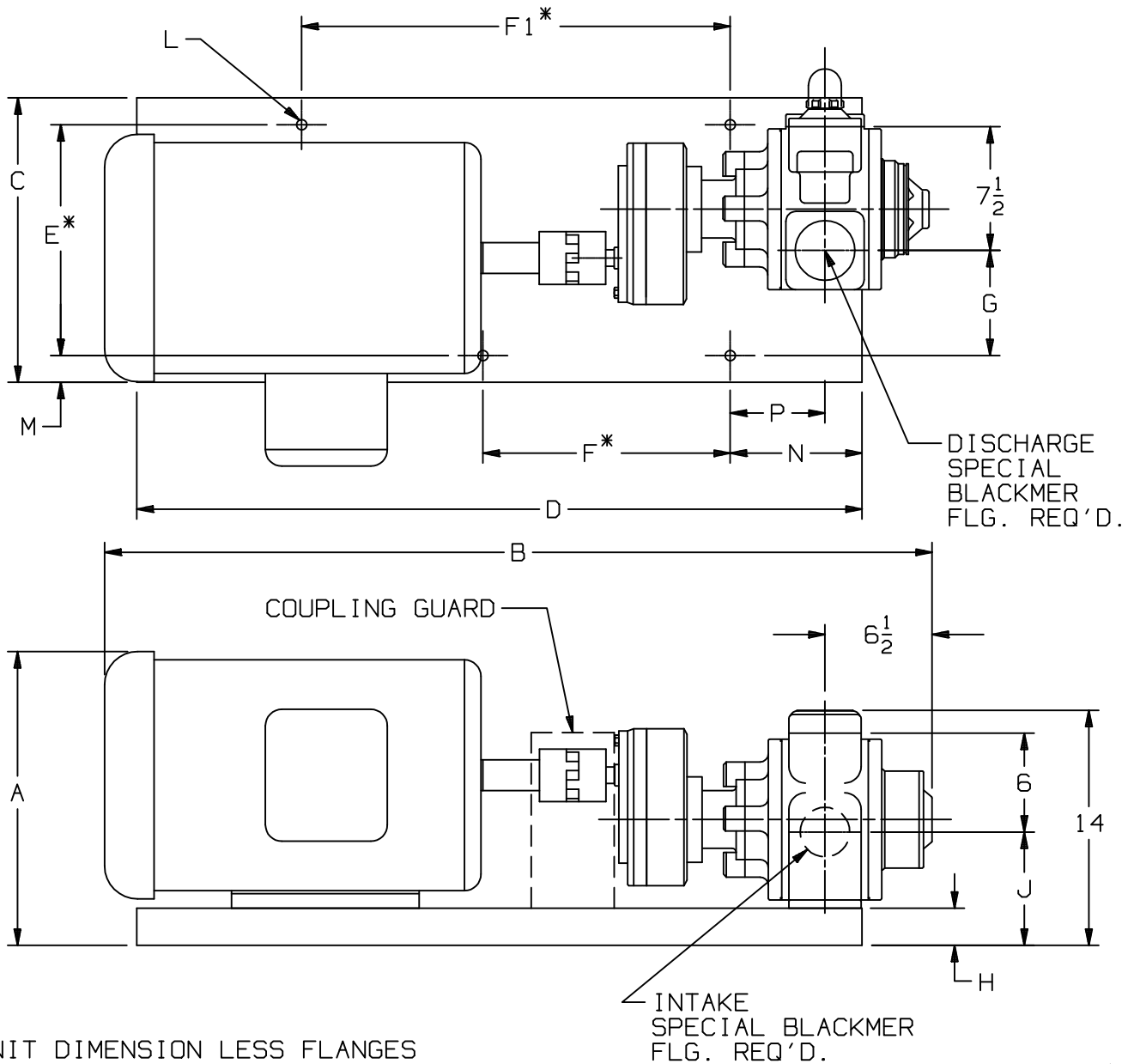

UNIT DIMENSION LESS FLANGES

* TOLERANCE $\pm \frac{1}{8}$

TOLERANCE ON OTHER DIMENSIONS $\pm \frac{1}{4}$

"A" DIMENSION LESS EYEBOLT

FLG. HT: 3" NPT-1 $\frac{1}{8}$

3" WELD-1 $\frac{3}{16}$

FRAME SIZE	MOTOR	UNITS	DIMENSIONS													
			A	B	C	D	E	F	F1	G	H	J	L	M	N	P
182T		901770	10 $\frac{7}{8}$	37 $\frac{3}{8}$	14 $\frac{3}{4}$	33	11 $\frac{1}{4}$	12	12	4 $\frac{7}{8}$	1 $\frac{3}{4}$	6 $\frac{3}{8}$	$\frac{7}{16}$	1 $\frac{3}{4}$	6	3 $\frac{1}{8}$
184T		901770	10 $\frac{7}{8}$	38 $\frac{3}{8}$	14 $\frac{3}{4}$	33	11 $\frac{1}{4}$	12	12	4 $\frac{7}{8}$	1 $\frac{3}{4}$	6 $\frac{3}{8}$	$\frac{7}{16}$	1 $\frac{3}{4}$	6	3 $\frac{1}{8}$
213T		901770	12 $\frac{3}{8}$	40 $\frac{7}{8}$	14 $\frac{3}{4}$	33	11 $\frac{1}{4}$	12	12	4 $\frac{7}{8}$	1 $\frac{3}{4}$	6 $\frac{3}{8}$	$\frac{7}{16}$	1 $\frac{3}{4}$	6	3 $\frac{1}{8}$
215T		901770	12 $\frac{3}{8}$	41 $\frac{5}{8}$	14 $\frac{3}{4}$	33	11 $\frac{1}{4}$	12	12	4 $\frac{7}{8}$	1 $\frac{3}{4}$	6 $\frac{3}{8}$	$\frac{7}{16}$	1 $\frac{3}{4}$	6	3 $\frac{1}{8}$
254T		901676	14 $\frac{3}{4}$	45 $\frac{1}{8}$	17 $\frac{1}{4}$	44	14	15	26	7	2 $\frac{1}{4}$	6 $\frac{7}{8}$	$\frac{5}{8}$	1 $\frac{5}{8}$	8	5 $\frac{1}{2}$
256T		901676	14 $\frac{3}{4}$	46 $\frac{7}{8}$	17 $\frac{1}{4}$	44	14	15	26	7	2 $\frac{1}{4}$	6 $\frac{7}{8}$	$\frac{5}{8}$	1 $\frac{5}{8}$	8	5 $\frac{1}{2}$