

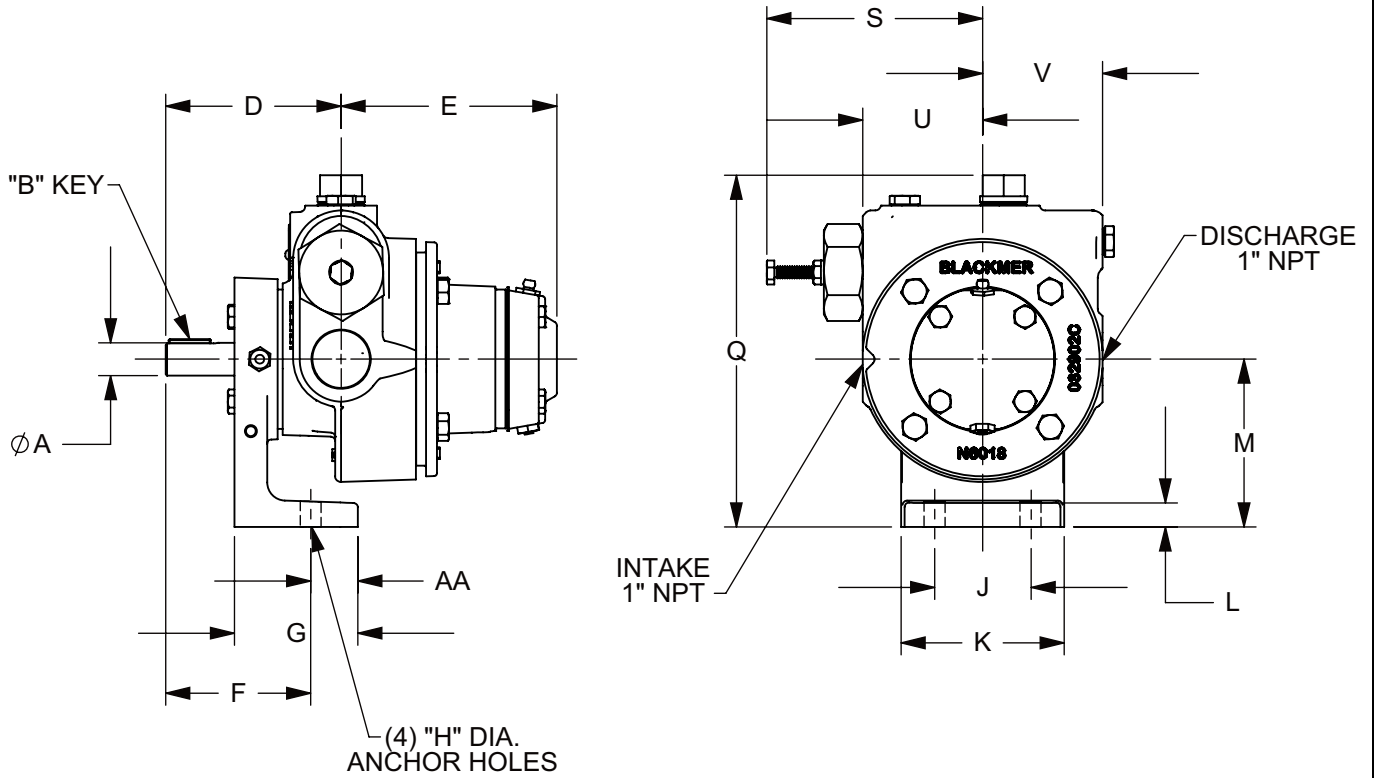

TYPE	SIZE	UNIT STYLE
XB	1C 1PC	PO

DIMENSIONS 101-102	
Section Effective Replaces Page 1 / 2	101 JUNE 2008 SEPTEMBER 2003



RIGHT HAND ROTATION

MOTOR			UNITS	DIMENSIONS									
FRAME SIZE				A	B	C	D	E	F	G	H	J	K
			IN	11/16	3/16	—	3 11/16	4 1/2	3	2 9/16	7/16	2	3 3/8
			MM	17,4	4,8	—	93,7	114,3	76,2	65,1	11,1	50,8	85,7
				L	M	N	P	Q	R	S	T	U	V
			IN	1/2	3 1/2	—	—	7 5/16	—	4 1/2	—	2 1/2	2 1/2
			MM	12,7	88,9	—	—	185,8	—	114,3	—	63,5	63,5
				W	X	Y	Z	AA	BB	CC	DD	EE	FF
			IN	—	—	—	—	1	—	—	—	—	—
			MM	—	—	—	—	25,4	—	—	—	—	—
				PUMP WEIGHT		WITH STD FLANGES							
				LBS		19							
				KG		8,6							

DIMENSIONS 101-102		TYPE	SIZE	UNIT STYLE	 www.blackmer.com
Section Effective Replaces Page 2 / 2	101 JUNE 2008 SEPTEMBER 2003	XB	1C 1PC	DM	

RIGHT HAND ROTATION

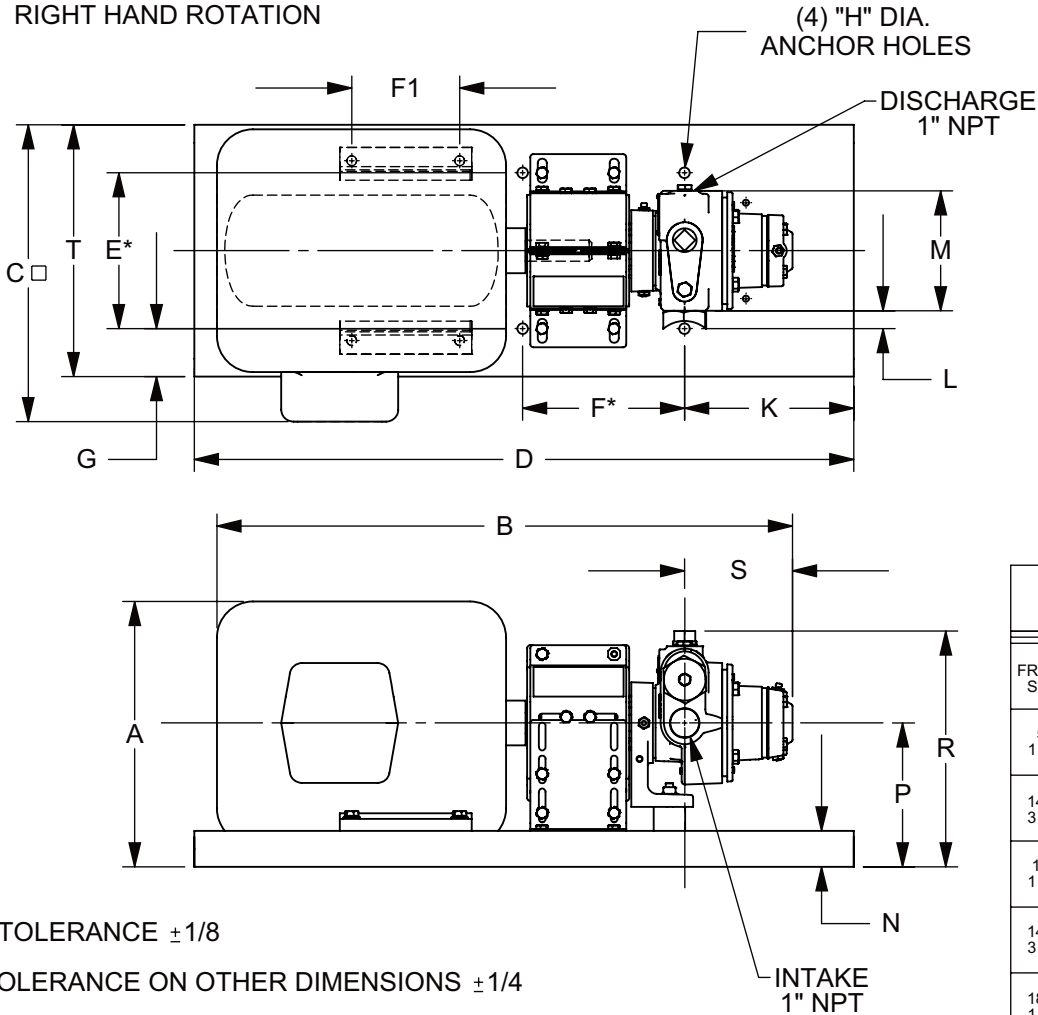

UNIT WEIGHT				
FRAME SIZE	H.P.	UNITS	LESS MOTOR	WITH MOTOR
56 1 PH	1		LBS	94
			KG	42
143T 3 PH	1		LBS	63
			KG	38
184 1 PH	1 1/2		LBS	118
			KG	53
145T 3 PH	1 1/2		LBS	95
			KG	43
182T 1 PH	2		LBS	127
			KG	57
145T 3 PH	2		LBS	95
			KG	43

* TOLERANCE ±1/8

TOLERANCE ON OTHER DIMENSIONS ±1/4

"A" DIMENSION LESS EYEBOLT

□ MAXIMUM UNIT WIDTH

MOTOR EXPLOSION PROOF 1800 RPM 60HZ			UNITS	DIMENSIONS																			
FRAME SIZE	H.P.	BASE NO.		A	B	C	D	E	F	F1	G	H	J	K	L	M	N	P	R	S	T	U	V
56 1 PH	1	901978	IN	9	24 3/4	12 3/4	27 1/2	6 1/2	6 3/4	3	2	7/16	---	7 1/16	3/4	5	1 1/2	5	9 1/4	4 3/8	10 1/2	---	---
			MM	228,6	628,7	323,9	698,5	165,1	171,5	76,2	50,8	11,1	---	179,4	19,1	127	38,1	127	234,9	111,1	266,7	---	---
143T 3 PH	1	901978	IN	9	23 5/8	12 3/4	27 1/2	6 1/2	6 3/4	4	2	7/16	---	7 1/16	3/4	5	1 1/2	5	9 1/4	4 3/8	10 1/2	---	---
			MM	228,6	600,1	323,9	698,5	165,1	171,5	101,6	50,8	11,1	---	179,4	19,1	127	38,1	127	234,9	111,1	266,7	---	---
184 1 PH	1 1/2	901978	IN	10 3/4	26 7/8	13 1/4	27 1/2	6 1/2	6 3/4	5 1/2	2	7/16	---	7 1/16	3/4	5	1 1/2	6	10 1/4	4 3/8	10 1/2	---	---
			MM	273,1	682,6	336,6	698,5	165,1	171,5	139,7	50,8	11,1	---	179,4	19,1	127	38,1	152,4	260,3	111,1	266,7	---	---
145T 3 PH	1 1/2	901978	IN	9	24 1/2	12 3/4	27 1/2	6 1/2	6 3/4	5	2	7/16	---	7 1/16	3/4	5	1 1/2	5	9 1/4	4 3/8	10 1/2	---	---
			MM	228,6	622,3	323,9	698,5	165,1	171,5	127	50,8	11,1	---	179,4	19,1	127	38,1	127	234,9	111,1	266,7	---	---
182T 1 PH	2	901978	IN	10 3/4	26 7/8	13 1/4	27 1/2	6 1/2	6 3/4	4 1/2	2	7/16	---	7 1/16	3/4	5	1 1/2	6	10 1/4	4 3/8	10 1/2	---	---
			MM	273,1	682,6	336,6	698,5	165,1	171,5	114,3	50,8	11,1	---	179,4	19,1	127	38,1	152,4	260,3	111,1	266,7	---	---
145T 3 PH	2	901978	IN	9	24 1/2	12 3/4	27 1/2	6 1/2	6 3/4	5	2	7/16	---	7 1/16	3/4	5	1 1/2	5	9 1/4	4 3/8	10 1/2	---	---
			MM	228,6	622,3	323,9	698,5	165,1	171,5	127	50,8	11,1	---	179,4	19,1	127	38,1	127	234,9	111,1	266,7	---	---